

Navy (Non-US) Surface Ship RE Series (FPRE 14kW, 17kW & 22kW) Electric Fryer

Installation, Operation and Maintenance Manual

This manual is updated as new information and models are released. Visit our website for the latest manual.

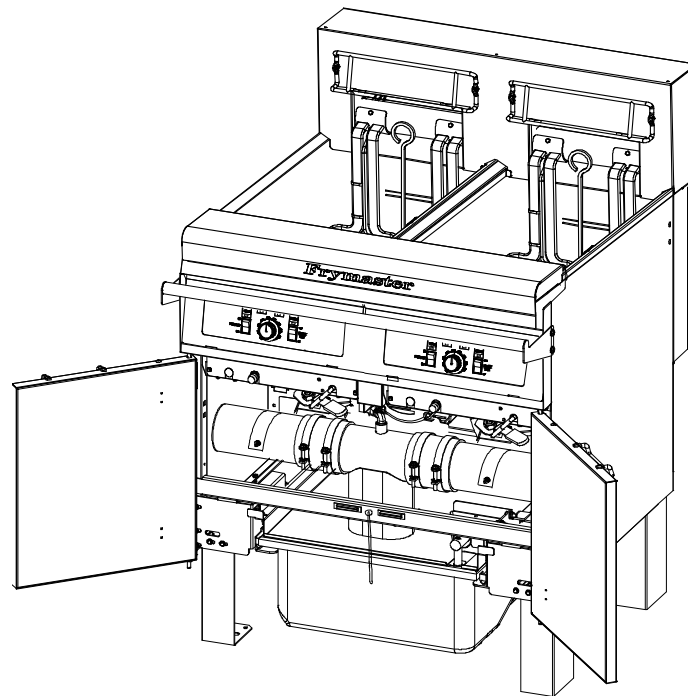

FOR YOUR SAFETY

**Do Not Store or use gasoline
or other flammable vapors
and liquids in the vicinity of
this or any other appliance.**

CAUTION

READ THE INSTRUCTIONS BEFORE USING THE FRYER.

Keep these instructions for future reference.



8 1 9 7 6 8 1

Part Number: FRY_IOM_8197681 04/2019

Original Instructions



Navy (Non-US) Surface Ship Electric Fryers Installation, Operation, Service, and Parts Manual

TABLE OF CONTENTS

	Page
Chapter 1: Introduction.....	1-1
Chapter 2: Installation Instructions.....	2-1
Chapter 3: Operating Instructions.....	3-1
Chapter 4: Filtration Instructions.....	4-1
Chapter 5: Preventive Maintenance.....	5-1
Chapter 6: Operator Troubleshooting.....	6-1
Chapter 7: Service Procedures.....	7-1
Chapter 8: Parts List.....	8-1

NAVY (NON-US) SURFACE SHIP ELECTRIC FRYERS

CHAPTER 1: INTRODUCTION

1.1 General

Read the instructions in this manual thoroughly before attempting to operate this equipment. This manual covers all configurations of Navy Surface Ship Electric Fryer models specifically configured for use aboard surface ships of the Navy system models. The fryers in this model family have most parts in common, and when discussed as a group, will be referred to as “Navy Surface Ship Electric” fryers.

The Navy Surface Ship Electric fryers feature a rotating element assembly. Other features include deep cold-zones, open frypots and an integrated filtration system. All Navy fryers are equipped with solid-state analog controllers. Fryers in this series can be single units or grouped in batteries of two or more fryers.

1.2 Safety Information

Before attempting to operate your unit, read the instructions in this manual thoroughly.

Throughout this manual, you will find notations enclosed in double-bordered boxes similar to the one below.

 DANGER Hot cooking oil causes severe burns. Never attempt to move a fryer containing hot cooking oil or to transfer hot cooking oil from one container to another.

 **CAUTION** boxes contain information about actions or conditions that *may cause or result in a malfunction of your system.*

 **WARNING** boxes contain information about actions or conditions that *may cause or result in damage to your system,* and which may cause your system to malfunction.

 **DANGER** boxes contain information about actions or conditions that *may cause or result in injury to personnel,* and which may cause damage to your system and/or cause your system to malfunction.

Fryers in this series are equipped with the following automatic safety features:

1. Two high-temperature detection features shut off power to the elements should the temperature controls fail.
2. A safety switch built into the drain valve prevents the elements from heating with the drain valve even partially open.

1.3 Controller Information

This equipment has been tested and found to comply with the limits for a Class A digital device, pursuant to Part 15 of the FCC rules. While this device is a verified Class A device, it has been shown to meet the Class B limits. These limits are designed to provide reasonable protection against harmful interference when the equipment is operated in a commercial environment. This equipment generates, uses and can radiate radio frequency energy and, if not installed and used in accordance with the instruction manual, may cause harmful interference to radio communications.

The user may find the following booklet prepared by the Federal Communications Commission helpful: "How to Identify and Resolve Radio-TV Interference Problems". This booklet is available from the U.S. Government Printing Office, Washington, DC 20402, Stock No. 004-000-00345-4.

1.4 Shipping Damage Claim Procedure

What to do if this equipment arrives damaged:

Please note that this equipment was carefully inspected and packed by skilled personnel before leaving the factory. The freight company assumes full responsibility for safe delivery upon acceptance of the equipment.

1. File Claim for Damages Immediately—Regardless of extent of damage.
2. Visible Loss or Damage—Be sure this is noted on the freight bill or express receipt and is signed by the person making the delivery.
3. Concealed Loss or Damage—If damage is unnoticed until equipment is unpacked, notify the freight company or carrier immediately and file a concealed damage claim. This should be done within 15 days of date of delivery. Be sure to retain container for inspection.

1.5 Service Information

For non-routine maintenance or repairs, or for service information, contact your local Frymaster Authorized Servicer (FAS). A list of Frymaster Factory Authorized Servicers (FAS's) is located on the Frymaster website at www.frymaster.com. Service information may also be obtained by calling the Frymaster Technical Services Department (1-800-551-8633) or via e-mail at service@frymaster.com. The following information will be needed in order to assist you efficiently:

Model Number: _____
Serial Number: _____
Voltage: _____

Also be prepared to describe the specific problem.

RETAIN AND STORE THIS MANUAL IN A SAFE PLACE FOR FUTURE USE.

NAVY (NON-US) SURFACE SHIP ELECTRIC FRYERS

CHAPTER 2: INSTALLATION INSTRUCTIONS

2.1 Introduction

The instructions in this chapter cover all configurations of Navy Surface Ship Electric Fryer models specifically configured for use aboard surface ships of the Non-US Navy. The instructions do not cover and may not be used for installations aboard submarines or ashore.

Proper installation is essential for the safe, efficient, trouble-free operation of this appliance. Any unauthorized alteration of this equipment will void the Frymaster warranty.

NOTICE

All fryers shipped without factory supplied cords and plug assemblies must be hardwired using flexible conduit to the terminal block located on the rear of the fryer. These fryers should be wired to National Electric Code (NEC) specifications. Hardwired units must include installation of restraint devices.

DANGER

Adequate means must be provided to limit the movement of this appliance without depending on or transmitting stress to the electrical conduit

NOTICE

If this equipment is wired directly into the electrical power supply, a means for disconnection from the supply having a contact separation of at least 3-mm in all poles must be incorporated in the fixed wiring.

NOTICE

This equipment must be positioned so that the plug is accessible unless other means for disconnection from the power supply (e.g., a circuit breaker) is provided.

NOTICE

If this appliance is permanently connected to fixed wiring, it must be connected by means of copper wires having a temperature rating of not less than 167°F (75°C).

NOTICE

If the electrical power supply cord is damaged, it must be replaced by a Frymaster Dean Factory Authorized Servicer technician or a similarly qualified person in order to avoid a hazard.

DANGER

This appliance must be connected to a power supply having the same voltage and phase as specified on the rating plate located on the inside of the appliance door.

⚠ DANGER

All wiring connections for this appliance must be made in accordance with the wiring diagram(s) furnished with the appliance. Refer to the wiring diagram(s) affixed to the inside of the appliance door when installing or servicing this equipment.

⚠ DANGER

The appliance area must be kept free and clear of combustible material at all times.

⚠ WARNING

Do not block the area around the base or under the fryers.

All installation and service on FRYMASTER equipment must be performed by qualified, certified, licensed, and/or authorized installation or service personnel.

Service may be obtained by contacting a local Frymaster Factory Authorized Servicer.

In the event of a power failure, the fryer(s) will automatically shut down. If this occurs, turn the power switch OFF. Do not attempt to start the fryer(s) until power is restored.

A clearance of 6 inches (15cm) must be provided at both sides and back adjacent to combustible construction. A minimum of 24 inches (61cm) should be provided at the front of the equipment for servicing and proper operation.

Connections should be made by means of an approved, flexible-metallic or rubber-covered electrical cable and quick-disconnect plug. The fryers may be installed with “hard-wired” connections but use of quick-disconnect plugs will facilitate service if required. Connections are made to the fryer power input terminal block located in lower back of the fryer(s).

⚠ DANGER

Observe the following precautions when connecting the fryer to an emergency cutoff system:

- **Be sure that each fryer is connected to a dedicated set of contacts in the emergency cutoff system. Do not connect more than one fryer to each set of contacts.**
- **Do not connect the contacts in series.**
- **The contacts MUST be normally closed contacts that open in an emergency.**
- **The contacts CANNOT have an external voltage applied.**

2.2 Power Requirements

MODEL	VOLTAGE	PHASE	WIRE SERVICE	MIN. SIZE	AWG (mm ²)	AMPS PER LEG		
						L1	L2	L3
FPRE14	440	3	3	8	(10)	19	19	19
FPRE14	480	3	3	8	(10)	17	17	17
FPRE17	440	3	3	6	(16)	23	23	23
FPRE17	480	3	3	6	(16)	21	21	21
FPRE22	440	3	3	6	(16)	29	29	29
FPRE22	480	3	3	6	(16)	27	27	27

The RE Navy Surface Ship electric fryers are equipped with a filter system that may require a separate 120VAC or 220VAC single-phase, 3-wire, 20-amp service (refer to wiring diagrams in chapter 7).

NOTICE

If this appliance is permanently connected to fixed wiring, it must be connected by means of copper wires having a temperature rating of not less than 167°F (75°C).

DANGER

This appliance must be connected to a power supply having the same voltage and phase as specified on the rating plate located on the inside of the appliance door.

DANGER

All wiring connections for this appliance must be made in accordance with the wiring diagram(s) furnished with the appliance. Refer to the wiring diagram(s) affixed to the inside of the appliance door when installing or servicing this equipment.

2.3 Installation

1. This equipment must be securely bolted to the deck.
2. Install deck studs for the specific fryer configuration in accordance with the diagrams at the end of this chapter.
3. Position the fryer on the deck studs and secure with appropriate nuts and lock washers.

DANGER

No structural material on the fryer should be altered or removed to accommodate placement of the fryer under a hood. Questions? Call the Frymaster Dean Service Hotline at 1-800-551-8633.

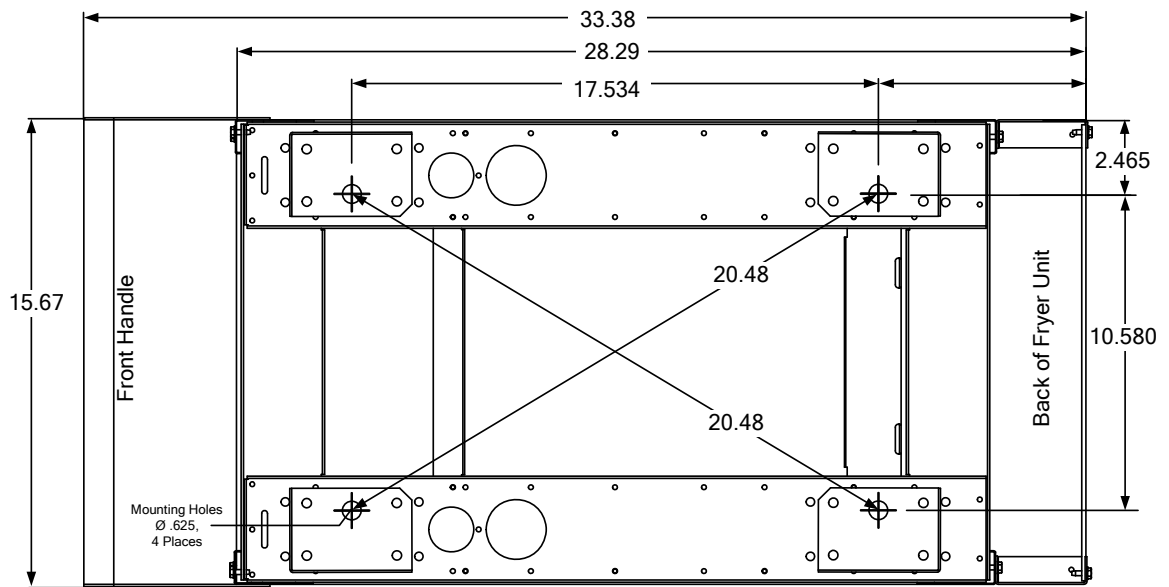

Single Fryer (non-filter)

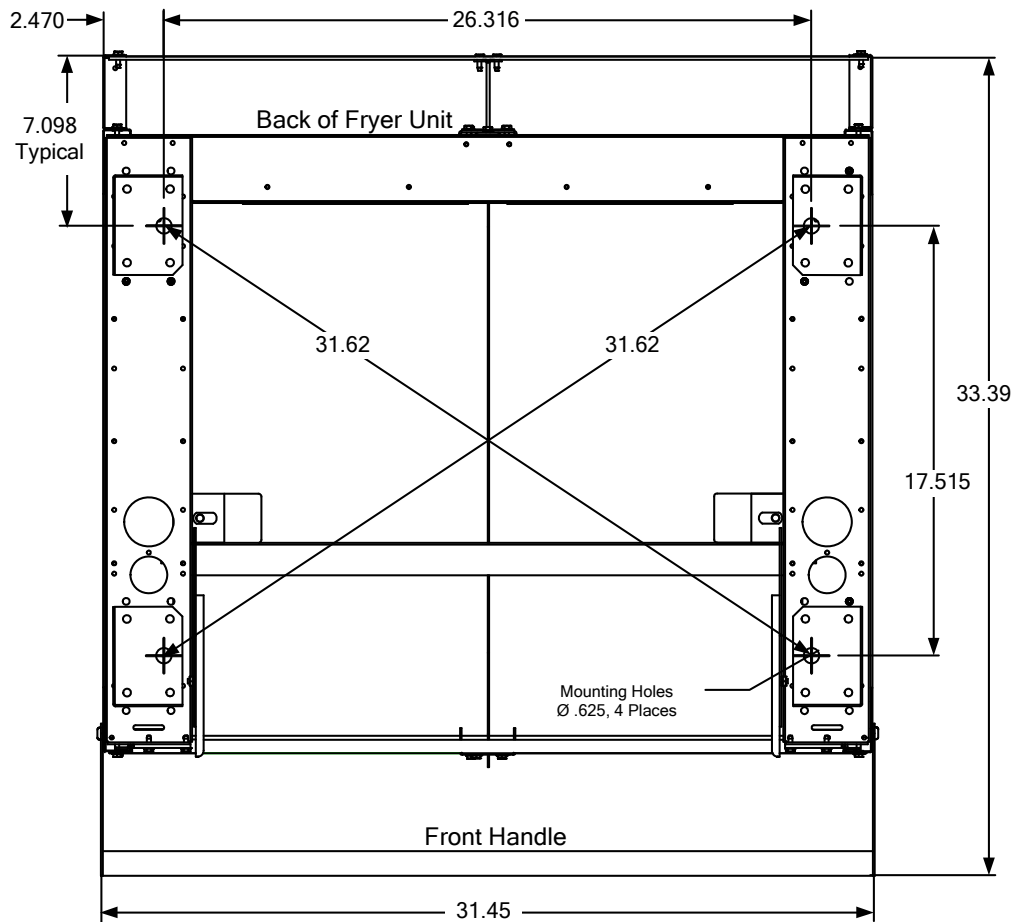

2-Fryer Battery

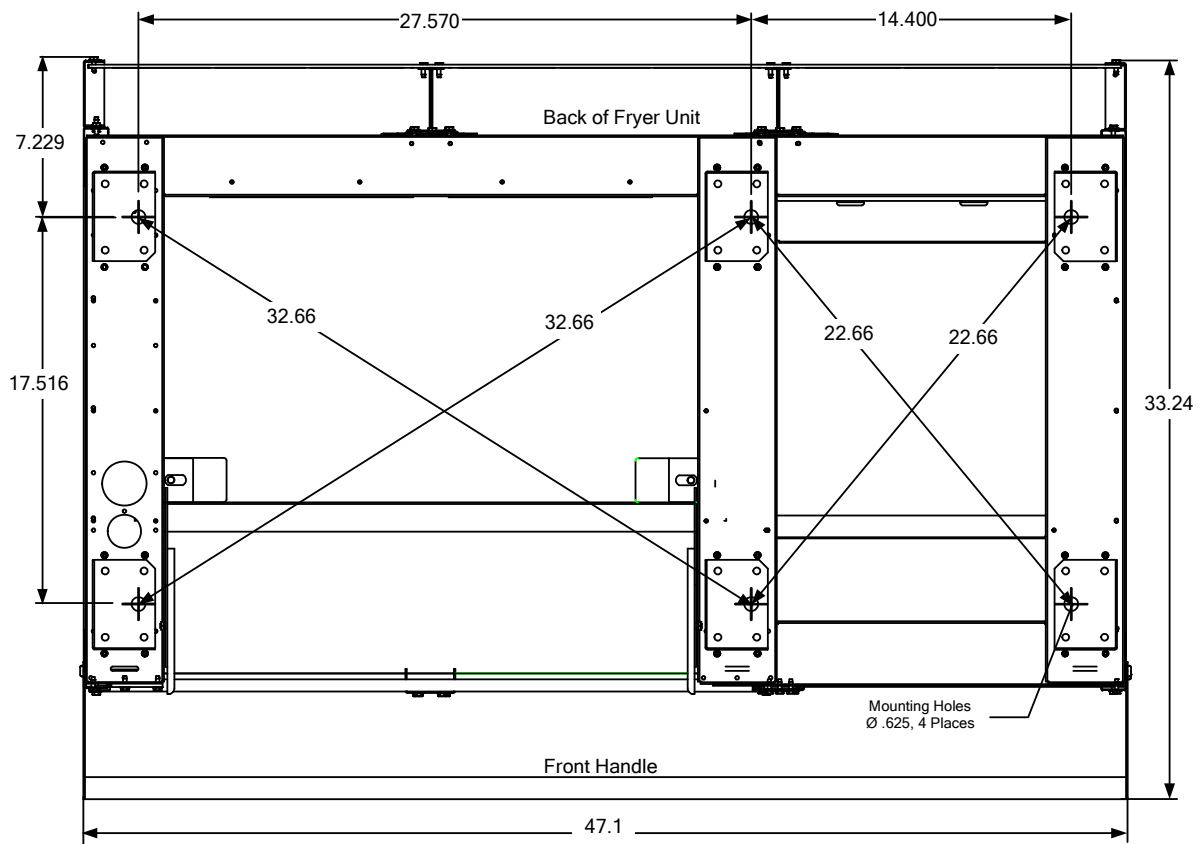

3-Fryer Battery

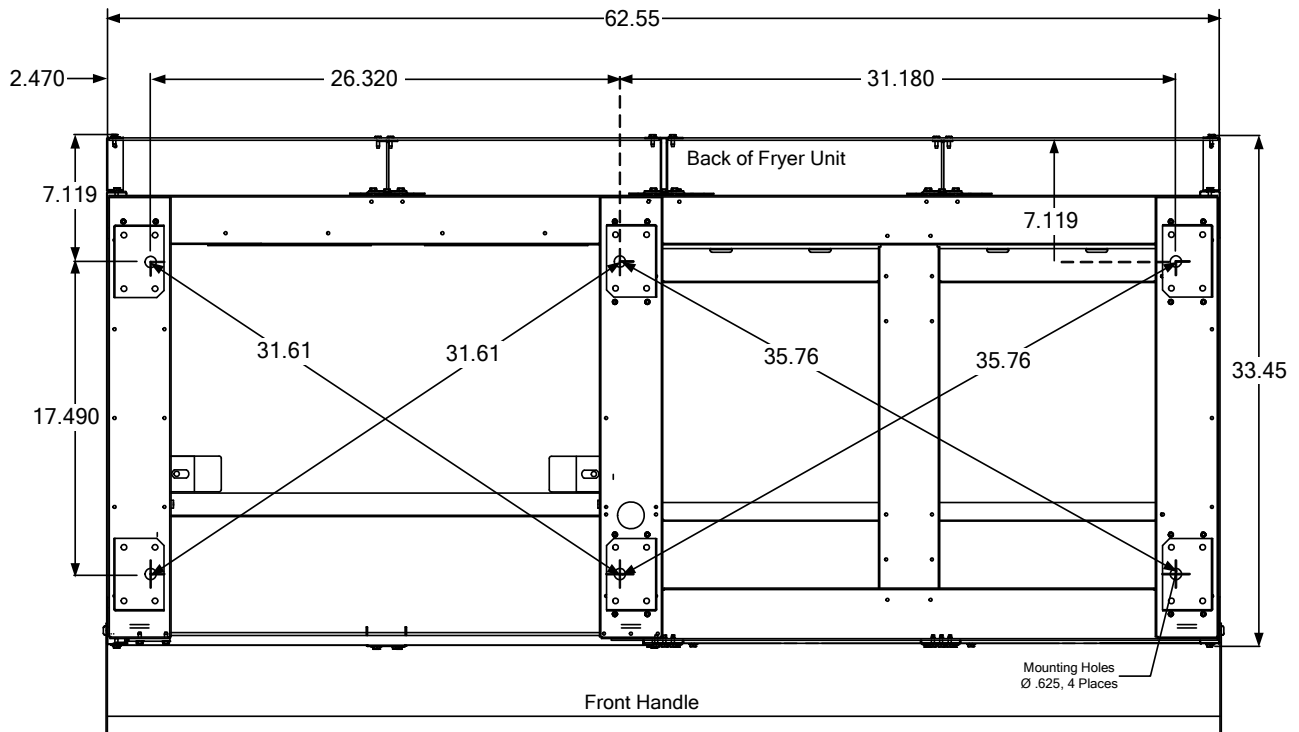

4-Fryer Battery

NAVY (NON-US) SURFACE SHIP ELECTRIC FRYERS

CHAPTER 3: OPERATING INSTRUCTIONS

3.1 Equipment Setup and Shutdown Procedures

Setup

⚠ DANGER

Never operate the appliance with an empty frypot. The frypot must be filled with water or cooking oil before energizing the elements. Failure to do so will result in irreparable damage to the elements and may cause a fire.

⚠ DANGER

Remove all drops of water from the frypot before filling with cooking oil. Failure to do so will cause spattering of hot liquid when the oil is heated to cooking temperature.

1. Fill the frypot with cooking oil to the bottom OIL LEVEL line located on the rear of the frypot. This will allow for oil expansion as heat is applied. Do not fill cold oil any higher than the bottom line; overflow may occur as heat expands the oil.

NOTE: If solid shortening is used, first raise the elements, then pack the shortening into the bottom of the frypot. Lower the elements, and then pack the shortening around and over the elements. It may be necessary to add shortening to bring the level up to the proper mark after the packed shortening has melted.

⚠ DANGER

Never set a complete block of solid shortening on top of the heating elements.

When using solid shortening, always pre-melt the shortening before adding it to the frypot. If the shortening is not pre-melted, it must be packed down into the bottom of the frypot and between the elements, and the fryer must be started in the melt-cycle mode.

Never cancel the melt-cycle mode when using solid shortening. Doing so will result in damage to the elements and increase the potential for a flash fire.

2. If the fryer(s) is/are not hard-wired into the power supply, ensure that the power cord(s) is/are plugged into the appropriate receptacle(s). Verify that the face of the plug(s) is/are flush with the outlet plate, with no portion of the prongs visible.
3. Ensure that the oil level is at the *top* OIL LEVEL line when the oil *is at its cooking temperature*. It may be necessary to add oil to bring the level up to the proper mark, *after it has reached cooking temperature*.

Shutdown

1. Turn the fryer off.
2. Filter the cooking oil and clean the fryers (See Chapters 4 and 5).
3. Place the frypot covers on the frypots.

3.2 Operation of the Solid-State Analog Controller

NOTE: Refer to Chapter 4 of this manual for operating instructions for the built-in filtration system.

Fryers configured for the Navy are equipped with solid-state analog controllers.

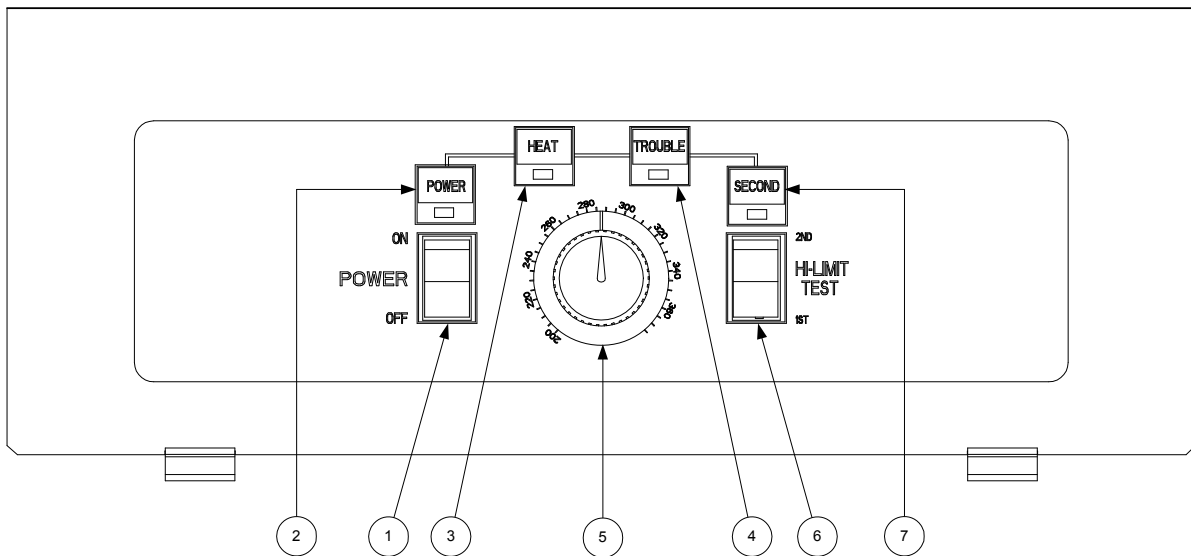

U.S. Navy Solid-State Analog Controller

ITEM	DESCRIPTION
1	Power Switch – Controls electrical power to fryer.
2	Power-On Light – Indicates when electrical power to fryer is ON.
3	Heating Mode Light – Indicates when heating element is ON.
4	Trouble Light – Indicates over high-limit or problem in heat control circuitry.
5	Thermostat Control Knob – Sets desired frying temperature.
6	Hi-Limit Test Switch – Tests high-limit thermostat.
7	Second Hi-Limit Test Light – Indicates fryer is in second high-limit test mode.

The analog controller, illustrated above, is used to adjust and maintain oil at the temperature indicated by the thermostat knob.

The fryer has two built-in high-limit protection features. If the temperature in the frypot reaches approximately 410°F, the controller opens the heat relay circuit, turning the elements off. If the temperature in the frypot reaches 450°F, a mechanical high-limit shuts off electrical power to the elements. ***The operator should periodically test each of the high-limit protection features, using the procedure at the end of this chapter, to verify that they are operating correctly.***

The analog controller has no timing features. The operator must monitor shake and pull times.

 **WARNING**

Before pressing the power switch to the ON position, ensure that the frypot is properly filled with oil. See Section 3.1.

CONTROLLER OPERATING PROCEDURE

1. Verify that the thermostat knob is set to the desired cooking temperature.
2. Press the power switch to the ON position. The POWER light will illuminate.
3. If the frypot temperature is below 180°F, the controller will automatically enter a warm-up cycle (often called a melt cycle). The heating elements will cycle on and off repeatedly, allowing the oil to heat gradually, without scorching. During the warm-up cycle, the heating mode light will alternately illuminate and go off as the elements cycle on and off. Within about 45 minutes, the controller will exit the warm-up cycle and the heating mode light will remain continuously illuminated.
4. When the oil temperature reaches the thermostat knob setpoint, the elements will cycle OFF and the HEAT light will go off, indicating that the fryer is ready for the cooking process to begin.

HIGH-LIMIT TEST PROCEDURE

Tools Required: One 0-600°F pyrometer with sensing probe or an equivalent high-temperature thermometer.

NOTE: Conduct this test when the fryer will not be needed for about one hour and when the cooking oil is due to be changed (the test will ruin the cooking oil). Start the test with the controller turned ON and with the cooking oil at normal frying temperature. Stir the oil thoroughly to ensure even distribution and temperature.

 **DANGER**

If the expected results (indicated by italics) for Steps 3 and 4 below do not occur, turn off the fryer at the main circuit breaker panel and do not use the fryer until it has been repaired by an authorized servicer.

1. Verify that cooking oil is at the bottom OIL-LEVEL line. Add oil if necessary.
2. Turn the power switch ON and set the control knob to the normal frying temperature.
3. Insert the pyrometer probe into the frypot so that its tip is near the temperature probe on the element (i.e., approximately 5-inches into the oil, near the center of the frypot). Press and hold the high-limit test switch in the “1st” test position until the TROUBLE light illuminates. Release the test switch.

The trouble light should have come on when the temperature was approximately 410°F (± 10°F) and the heating elements should have de-energized (indicated by the HEAT light going out).

4. Press and hold the high-limit test switch in the “2nd” test position until the 2nd High-Limit light illuminates. Release the switch.

The 2nd High-Limit light should have come on when the temperature was between 430°F and 460°F.

For fryers connected to an external shunt power supply, all fryers should have been shut off completely and all control panel lights should have been extinguished. For fryers not connected to an external shunt power supply, only the fryer being tested should have been shut off.

5. Place the controller power switch in the OFF position.
6. Allow the cooking oil to cool to below normal frying temperature. When the power switch is again placed in the ON position, the elements should re-energize and the operating thermostat should resume control of the temperature. If the TROUBLE light remains on instead, allow the oil additional time to cool.

NAVY (NON-US) SURFACE SHIP ELECTRIC FRYERS

CHAPTER 4: FILTRATION INSTRUCTIONS

4.1 Introduction

The FootPrint Pro filtration system allows the cooking oil or shortening in one frypot to be safely and efficiently filtered while the other frypots in a battery remain in operation. Section 4.2 covers preparation of the filter system for use. Operation of the system is covered in section 4.3.

⚠ WARNING

The work center supervisor is responsible for ensuring that operators are made aware of the inherent hazards of operating a hot oil filtering system, particularly the aspects of oil filtration, draining and cleaning procedures.

4.2 Preparing the Filter for Use

1. Rotate the pan-locking rod to either side until it clears the filter pan, then pull the pan out from the cabinet. Remove the crumb tray, hold-down ring and filter screen. Clean all components with a solution of detergent and hot water then dry thoroughly.

The filter pan is equipped with rollers in rails, much like a kitchen drawer. The pan may be removed for cleaning or to gain access to interior components by lifting the front of the pan to disengage the front rollers, then pulling it forward until the rear rollers clear the rails. The pan cover must not be removed except for cleaning, interior access, or to allow a Shortening Disposal Unit (SDU) to be positioned under the drain.

2. Inspect the filter pan connection fitting to ensure that both O-rings are in good condition. O-rings are located on the tube disconnect inside the filter pan as shown to the right.

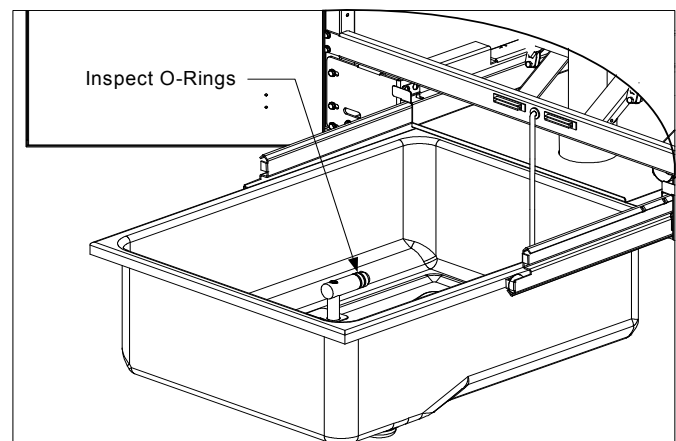
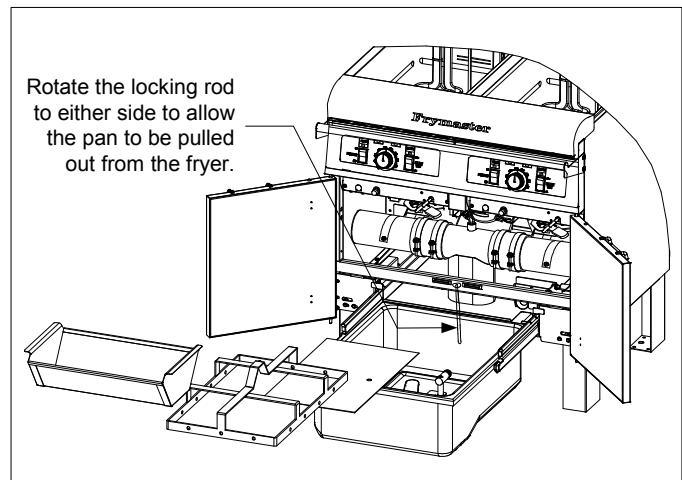

- Place the metal filter screen in the center of the bottom of the pan, then lay a sheet of filter paper on top of the screen, overlapping on all sides.
- Position the hold-down ring over the filter paper and lower the ring into the pan, allowing the paper to fold up around the ring as it is lowered to the bottom of the pan.
- When the hold-down ring is in position, sprinkle one packet of filter powder evenly over the paper.
- Replace the crumb tray in the filter pan, then push the filter pan back into the fryer, positioning it under the drain.

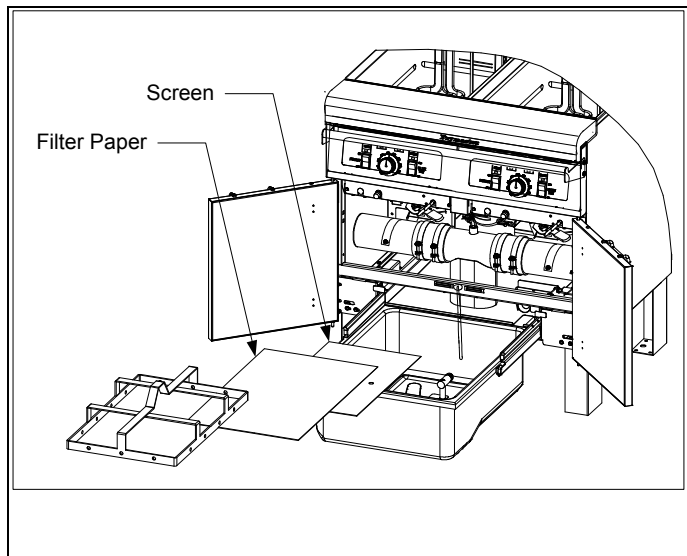

4.3 Operation of the Filter

⚠ DANGER

Draining and filtering of cooking oil must be accomplished with care to avoid the possibility of a serious burn caused by careless handling. The oil to be filtered is at or near 350°F. Ensure drain handles are in their proper position before operating any switches or valves. Wear all appropriate safety equipment when draining and filtering cooking oil or shortening.

⚠ DANGER

NEVER attempt to drain cooking oil from the fryer with the elements energized! Doing so will cause irreparable damage to the elements and may cause a flash fire. Doing so will also void the Frymaster warranty.

- Ensure that the filter is prepared. See Sec. 4.2.
- Make sure the oil is at operating temperature.
- Turn the fryer power OFF. Drain the frypot into the filter pan by rotating the valves 90°. If necessary, use the *Fryer's Friend* clean-out rod to clear the drain from **inside** the frypot. It will be necessary to lift the elements and remove the basket support rack to use the *Fryer's Friend*.

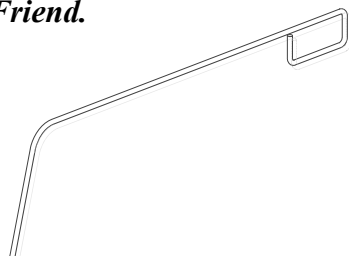

Fryer's Friend

⚠ DANGER

Do not drain more than one frypot at a time into the built-in filtration unit to avoid overflow and spillage of hot oil.

⚠ DANGER

NEVER attempt to clear a clogged drain valve from the front of the valve! Hot oil will rush out creating the potential for severe burns. DO NOT hammer on the drain valve with the cleanout rod or other objects. Damage to the ball inside will result in leaks and will void the Frymaster warranty.

4. After the cooking oil has drained from the frypot, turn the filter handle to the ON position to start the pump and begin the filtering process. There may be a slight delay before the pump activates.

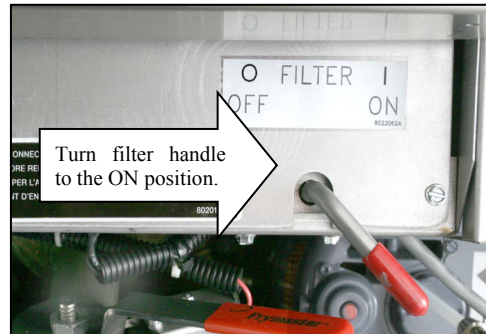

5. The filter pump draws the cooking oil through the filter medium and circulates it back up to and through the frypot during a 5-minute process called polishing. Polishing cleans the oil by trapping solid particles in the filter medium.
6. After the oil is filtered (about 5 minutes), close the drain valve and allow the fryer to refill. Let the filter pump run 10 to 12 seconds after the oil begins to bubble. Turn the filter off.

⚠ WARNING

The filter pump is equipped with a manual reset switch (see photo below) in case the filter motor overheats or an electrical fault occurs. If this switch trips, turn off power to the filter system and allow the pump motor to cool 20 minutes before attempting to reset the switch.

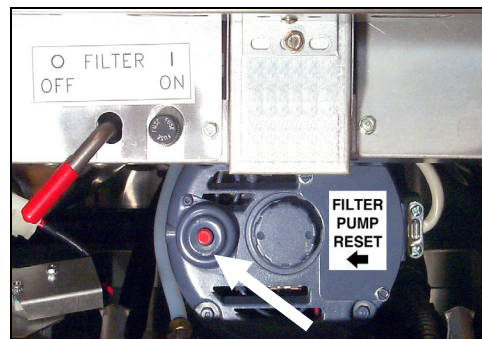

Filter Pump Reset Switch

7. Lower the elements into the frypot and reinstall the basket support rack if they were raised to clear the drain. Ensure the drain valve is fully closed. (If the drain valve is not fully closed, the fryer will not operate.) Turn the fryer ON and allow the cooking oil to reach setpoint.

 DANGER

The crumb tray must be emptied into a fireproof container at the end of frying operations each day. Some food particles can spontaneously combust if left soaking in certain shortening.

 WARNING

Do not bang fry baskets or other utensils on the fryer's joiner strip. The strip is present to seal the joint between the fry vessels. Banging fry baskets on the strip to dislodge shortening will distort the strip, adversely affecting its fit. It is designed for a tight fit and should only be removed for cleaning.

4.4 Draining and Disposing of Waste Oil

When your cooking oil has reached the end of its usable life, drain the oil into an appropriate METAL container for transport to the disposal container. Frymaster recommends the use of the Shortening Disposal Unit (SDU).

NOTE: If using a Shortening Disposal Unit (SDU) built before January 2004 the filter pan cover must be removed to allow the unit to be positioned beneath the drain. To remove the lid, lift up on the front edge and pull it straight out of the cabinet.

Refer to the documentation furnished with the disposal unit for specific operating instructions. If a Shortening Disposal Unit (SDU) is not available, allow the oil to cool to 100°F, then drain the oil into a metal stockpot or similar metal container. When draining is finished, close the fryer drain valve securely.

 DANGER

Allow oil to cool to 100°F before draining into an appropriate container for disposal. When draining oil into a disposal unit, do not fill above the maximum fill line located on the container.

NAVY (NON-US) SURFACE SHIP ELECTRIC FRYERS

CHAPTER 5: PREVENTIVE MAINTENANCE

5.1 Cleaning the Fryer

 **DANGER**

The crumb tray in fryers equipped with a filter system must be emptied into a fireproof container at the end of frying operations each day. Some food particles can spontaneously combust if left soaking in certain shortening material.

 **DANGER**

Never attempt to clean the fryer during the frying process or when the frypot is filled with hot oil. If water comes in contact with oil heated to frying temperature, it will cause spattering of the oil, which can result in severe burns to nearby personnel.

 **WARNING**

Use a commercial-grade cleaner formulated to effectively clean and sanitize food-contact surfaces. Read the directions for use and precautionary statements before use. Particular attention must be paid to the concentration of cleaner and the length of time the cleaner remains on the food-contact surfaces.

5.1.1 Clean Inside and Outside of the Fryer Cabinet – Daily

Clean inside the fryer cabinet with a dry, clean cloth. Wipe all accessible metal surfaces and components to remove accumulated oil/shortening and dust.

Clean outside the fryer cabinet, with a clean, damp cloth soaked with dishwashing detergent. Wipe with a clean, damp cloth.

5.1.2 Clean the Built-in Filtration System – Daily

 **WARNING**

Never drain water into the filter pan. Water will damage the filter pump.

There are no periodic preventive maintenance checks and services required for the FootPrint Pro Filtration System other than daily cleaning of the filter pan and associated components with a solution of hot water and detergent.

5.1.3 Clean the Frypot and Heating Elements – Weekly

 DANGER

Never operate the appliance with an empty frypot. The frypot must be filled with water or cooking oil before energizing the elements. Failure to do so will result in irreparable damage to the elements and may cause a fire.

Boiling Out the Frypot

Before the fryer is first used, it should be boiled out to ensure that residue from the manufacturing process has been eliminated. Also, after the fryer has been in use for a period of time, a hard film of caramelized vegetable oil will form on the inside of the frypot. This film should be periodically removed by following the boil-out procedure that follows.

1. Before switching the fryer(s) ON, close the frypot drain valve(s), then fill the empty frypot with a mixture of cold water and dishwashing detergent. Follow instructions on detergent container when mixing.
2. Press the fryer ON/OFF switch to the ON position.
3. Set the temperature control knob to the lowest setting.
4. Simmer the solution for 45 minutes to one hour. Do not allow the water level to drop below the bottom oil-level line in the frypot during the boil-out operation.

 DANGER

Never leave the fryer unattended during the boil-out process. If the boil-out solution boils over, turn the fryer off immediately and let the solution cool for a few minutes before resuming the process.

5. Turn the fryer ON/OFF switch(s) to the OFF position.
6. Add two gallons of water. Drain out the solution and clean the frypot(s) thoroughly.

 WARNING

Do not drain boil-out solution into a Shortening Disposal Unit, a built-in filtration unit, or a portable filter unit. These units are not intended for this purpose, and will be damaged by the solution.

7. Refill the frypot(s) with clean water. Rinse the frypot(s) twice, drain and dry with a clean towel. Thoroughly remove all water from the frypot and elements before refilling the frypot with cooking oil.

 DANGER

Remove all drops of water from the frypot before filling with cooking oil. Failure to do so will cause spattering of hot liquid when the oil is heated to cooking temperature.

5.1.4 Clean Detachable Parts and Accessories – Weekly

Wipe all detachable parts and accessories with a clean, dry cloth. Use a clean cloth saturated with detergent to remove accumulated carbonized oil on detachable parts and accessories. Rinse the parts and accessories thoroughly with clean water and wipe dry before reinstalling.

5.2 Check Calibration of Temperature Control Knob – Monthly

1. After the cooking oil reaches operating temperature, let the heating elements cycle at least four times (indicated by the HEAT light going out and coming back on).
2. Insert a thermometer or pyrometer probe near the temperature-sensing probe approximately five inches deep into the cooking oil. When the heating elements cycle on for the fourth time, the thermometer should read within $\pm 5^{\circ}\text{F}$ of the temperature control knob setting.
3. If the knob requires adjustment:
 - a. Loosen the setscrew in the control knob until the outer shell of the knob will rotate on the insert inside the knob.
 - b. Rotate the outer shell of the knob until the index line on the knob aligns with the mark that corresponds to the thermometer or pyrometer reading.
 - c. Hold the knob and tighten the setscrew.
 - d. Recheck the thermometer or pyrometer reading and the temperature control knob setting the next time the HEAT light illuminates.
 - e. Repeat steps a through d until the thermometer or pyrometer reading and the knob setting agree within 5°F .

5.3 Annual/Periodic System Inspection

This appliance should be inspected and adjusted periodically by qualified service personnel as part of the galley material maintenance management (3M) program.

Frymaster recommends that a Factory Authorized Servicer inspect this appliance at least annually as follows:

Fryer

- Inspect the cabinet inside and out, front and rear for excessive oil.
- Verify that the heating element wires are in good condition and that leads have no visible fraying or insulation damage and that they are free of oil.
- Verify that heating elements are in good condition with no carbon/caramelized oil build-up. Inspect the elements for signs of extensive dry-firing.
- Verify that the tilt mechanism is working properly when lifting and lowering elements, and that the element wires are not binding and/or chafing.
- Verify the heating-element amp-draw is within the allowed range as indicated on the appliance's rating plate.
- Verify that the temperature and high-limit probes are properly connected, tightened and functioning properly, and that mounting hardware and probe guards are present and properly installed.
- Verify that component box and contactor box components (i.e. controller, relays, interface boards, transformers, contactors, etc.) are in good condition and free from oil and other debris. Verify that component box and contactor box wiring connections are tight, and that wiring is in good condition.
- Verify that all safety features (i.e. contactor shields, drain safety switches, reset switches, etc.) are present and functioning properly.
- Verify that the frypot is in good condition and free of leaks and that the frypot insulation is in serviceable condition.
- Verify that all wiring harnesses and wiring connections are tight and in good condition.

Built-In Filtration System

- Inspect all oil-return and drain lines for leaks and verify that all connections are tight.
- Inspect the filter pan for leaks and cleanliness. If there is a large accumulation of crumbs in the crumb basket, instruct the work center supervisor/watch supervisor that the crumb basket must be emptied into a fireproof container and cleaned daily.
- Verify that all O-rings and seals (including those on the quick-disconnect fittings) are present and in good condition. Replace O-rings and seals if worn or damaged.

- Check filtration system integrity as follows:
- Verify that filter pan cover is present and properly installed.
- With the filter pan empty, place each oil return handle, one at a time, in the ON position. Verify that the pump activates and that bubbles appear in the oil of the associated frypot.
- Close all oil return valves (i.e., place all oil return handles in the OFF position). Verify proper functioning of each oil return valve by activating the filter pump using the lever on one of the oil return handle microswitches. No air bubbles should be visible in any frypot.
- Verify that the filter pan is properly prepared for filtering, then drain a frypot of oil heated to 350°F into the filter pan and close the frypot drain valve. Place the oil return handle in the ON position. Allow all oil to return to the frypot indicated by bubbles in the cooking oil. Return the oil return handle to the OFF position. The frypot should have refilled in no more than 2 minutes and 30 seconds.

NAVY (NON-US) SURFACE SHIP ELECTRIC FRYERS

CHAPTER 6: OPERATOR TROUBLESHOOTING

6.1 Introduction

This section provides an easy reference guide to some of the common problems that may occur during the operation of this equipment. The troubleshooting guides that follow are intended to help correct, or at least accurately diagnose, problems with this equipment. Although the chapter covers the most common problems reported, you may encounter problems that are not covered. In such instances, the Frymaster Technical Services staff will make every effort to help you identify and resolve the problem.

When troubleshooting a problem, always use a process of elimination starting with the simplest solution and working through to the most complex. Never overlook the obvious – anyone can forget to plug in a cord or fail to close a valve completely. Most importantly, always try to establish a clear idea of why a problem has occurred. Part of any corrective action involves taking steps to ensure that it doesn't happen again. If a controller malfunctions because of a poor connection, check all other connections, too. If a fuse continues to blow, find out why. Always keep in mind that failure of a small component may often be indicative of potential failure or incorrect functioning of a more important component or system.

Before calling a service agent or the Frymaster HOTLINE (1-800-551-8633) or contacting via e-mail at fryservice@welbilt.com:

- **Verify that power is connected and that circuit breakers are on.**
- **Verify that frypot drain valves are fully closed.**

 **DANGER**

Hot cooking oil will cause severe burns. Never attempt to move this appliance when filled with hot cooking oil or to transfer hot cooking oil from one container to another.

 **DANGER**

This equipment should be disconnected from the electrical power supply when servicing, except when electrical circuit tests are required. Use extreme care when performing such tests.

This appliance may have more than one electrical power supply connection point. Disconnect all power supplies before servicing.

Inspection, testing, and repair of electrical components should be performed by authorized personnel only.

6.2 Troubleshooting

6.2.1 Control and Heating Problems

Problem	Probable Causes	Corrective Action
<p>Controller won't activate.</p>	<p>A. Power cord is not plugged in or circuit breaker is tripped.</p>	<p>A. Plug power cord in and verify that circuit breaker is not tripped.</p>
	<p>B. Controller has failed.</p>	<p>B. If available, substitute a controller known to be working for the suspect controller. If the substitute controller functions correctly, order a new controller.</p>
	<p>C. Power supply component or interface board has failed.</p>	<p>C. If any of the components in the power supply system (including the transformer and interface board) fail, power will not be supplied to the controller and it will not function. Determining which component has failed is beyond the scope of operator troubleshooting. Call FAS.</p>
<p>Fryer does not heat.</p>	<p>A. Drain valve is open.</p>	<p>A. This fryer is equipped with a drain safety switch that prevents the heating element from being energized if the drain valve is not fully closed. Verify that the drain valve is fully closed.</p>
	<p>B. Controller has failed.</p>	<p>B. If available, substitute a controller known to be working for the suspect controller. If the substitute controller functions correctly, order a new controller.</p>
	<p>C. One or more other components have failed.</p>	<p>C. If the circuitry in the fryer control system cannot determine the frypot temperature, the system will not allow the element to be energized or will de-energize the element if it is already energized. If the contactor, element, or associated wiring fails, the element will not energize. Determining which specific component is malfunctioning is beyond the scope of operator troubleshooting. Call FAS.</p>

Problem	Probable Causes	Corrective Action
Fryer repeatedly cycles on and off when first started.	Fryer is in melt-cycle mode.	This is normal. The standard operational mode for the controller is for the elements to cycle on and off until the temperature in the frypot reaches 180°F (82°C). The purpose of the melt-cycle is to allow controlled melting of solid shortening to prevent scorching and flash fires or damage to the element.
Fryer does not heat after filtering.	Drain valve is open.	This fryer is equipped with a drain safety switch that prevents the heating element from being energized if the drain valve is not fully closed. Verify that the drain valve is fully closed.
Fryer heats until high limit trips with heat indicator ON.	Temperature probe or controller has failed.	If available, substitute a controller known to be working for the suspect controller. If the substitute controller functions correctly, order a new controller. If substitution of the controller does not resolve the problem, the most likely cause is a failed temperature probe.
Fryer heats until high limit trips without heat indicator ON.	Contactor or controller has failed.	If available, substitute a controller known to be working for the suspect controller. If the substitute controller functions correctly, order a new controller. If substitution of the controller does not resolve the problem, the most likely cause is a contactor failed in the closed position.
Fryer stops heating with heat indicator ON.	The high limit thermostat or contactor has failed.	The fact that the heat indicator is ON indicates that the controller is functioning properly and is calling for heat. The high limit thermostat functions as a normally closed switch. If the thermostat fails, the "switch" opens and power to the elements is shut off. If the contactor fails to close, no power is supplied to the elements. Determining which component has failed is beyond the scope of operator troubleshooting. Call FAS.

6.2.2 Error Messages and Display Problems

Problem	Probable Causes	Corrective Action
Controller trouble light ON.	Oil temperature above acceptable range or a problem with the temperature measuring circuitry.	This is an indication of a malfunction in the temperature measuring or control circuitry, including a failure of the high limit thermostat. Determining the specific problem is beyond the scope of operator troubleshooting. Shut the fryer down immediately. Call FAS.
Controller trouble light ON and heating mode light ON.	Open drain valve or problem with latching circuits	Verify that the drain valve is fully closed. The fryer will not function if the drain valve is not fully closed. If the drain valve is fully closed, the problem is within the latching circuitry and is beyond the scope of operator troubleshooting. Call FAS.

6.2.3 Filtration Problems

Problem	Probable Causes	Corrective Action
Filter pump won't start.	A. Power cord is not plugged in or circuit breaker is tripped.	A. Verify that the power cord is fully plugged in. If so, verify that circuit breaker is not tripped.
	B. Pump motor has overheated causing the thermal overload switch to trip.	B. If the motor is too hot to touch for more than a few seconds, the thermal overload switch has probably tripped. Allow the motor to cool at least 20 minutes then press the Pump Reset Switch.
	C. Blockage in filter pump. Test: Close the drain valve and pull the filter pan out from the fryer. Activate the pump. If the pump motor hums for a short time then stops, the probable cause is blockage of the pump itself.	C. Pump blockages are usually caused by sediment buildup in the pump due to improperly sized or installed filter paper and failure to use the crumb screen.

(continued on following page)

Problem	Probable Causes	Corrective Action
<p>Filter pump runs but oil does not return to frypot and there is no bubbling oil.</p>	<p>Blockage in filter pan suction tube.</p> <p>Test: Close the drain valve and pull the filter pan out from the fryer. Activate the pump. If bubbling oil occurs, there is a blockage in the filter pan suction tube.</p>	<p>The blockage may be caused by sediment buildup or, if solid shortening is used, solidified shortening in the tube. Use a thin, flexible wire to remove the blockage. If the blockage cannot be removed, call FAS.</p>
<p>Filter pump runs, but oil return is very slow and bubbling oil occurs.</p>	<p>A. Improperly installed filter pan components.</p> <p>B. Attempting to filter with oil or shortening that is not hot enough.</p>	<p>A. Verify that filter screen is in bottom of filter pan with paper on top of the filter screen.</p> <p>Verify that O-rings are present and in good condition on filter pan connection fitting.</p> <p>B. In order to properly filter, the oil or shortening should be at or near 350°F (177°C). At temperatures lower than this, the oil becomes too thick to pass through the filter medium easily, resulting in much slower oil return and eventual overheating of the filter pump motor. Make sure oil is at or near frying temperature before draining oil into filter pan.</p>

NAVY (NON-US) SURFACE SHIP ELECTRIC FRYERS

CHAPTER 7: SERVICE PROCEDURES

7.1 General

Before performing any maintenance on this equipment, disconnect the fryer from the electrical power supply.

When electrical wires are disconnected, it is recommended that they be marked in such a way as to facilitate re-assembly.

7.2 Replacing a Controller

1. Disconnect the fryers from the electrical power supply.
2. The controller bezel is held in place by tabs at the top and bottom or by screws under the bezel. Slide the bezel up to disengage the lower tabs. Then slide the bezel down to disengage the upper tabs and tilt down. If applicable, remove the top two screws holding the controller to the control panel frame. The control panel is hinged at the bottom and will swing open from the top.
3. Unplug the wiring harness from the connector on the back of the controller and disconnect the grounding wire from terminal adjacent to the connector. Remove the control panel assembly by lifting it from the hinged slots in the control panel frame.



4. Remove the controller from the control panel assembly and install the replacement controller. Reinstall the control panel assembly by reversing steps 2 and 3.
5. Reconnect fryer to electrical power supply.

7.3 Replacing Component Box Components

1. Remove the control panel (see steps 1 - 3 of section 7.2).
2. Unplug the wiring harness from the 15-pin connector on the interface board and disconnect the grounding wire from terminal adjacent to the 15 or 20-pin connector on the back of the controller. Remove the control panel assembly by lifting it from the hinge slots in the control panel frame.

3. Disconnect the wiring from the component to be replaced, being sure to make a note of where each wire was connected.
4. Dismount the component to be replaced and install the new component, being sure that any required spacers, insulation, washers, etc. are in place.

NOTE: If more room to work is required, the control panel frame assembly may be removed by removing the hex head screws that secure it to the fryer cabinet (see illustration below). If this option is chosen, all front panel assemblies must be removed per steps 1-4 above. The cover plate on the lower front of the component box may also be removed if desired. *Removing the component box itself from the fryer is not recommended due to the difficulty involved in disconnecting and reconnecting the oil-return valve rods, which pass through openings in the component box.*

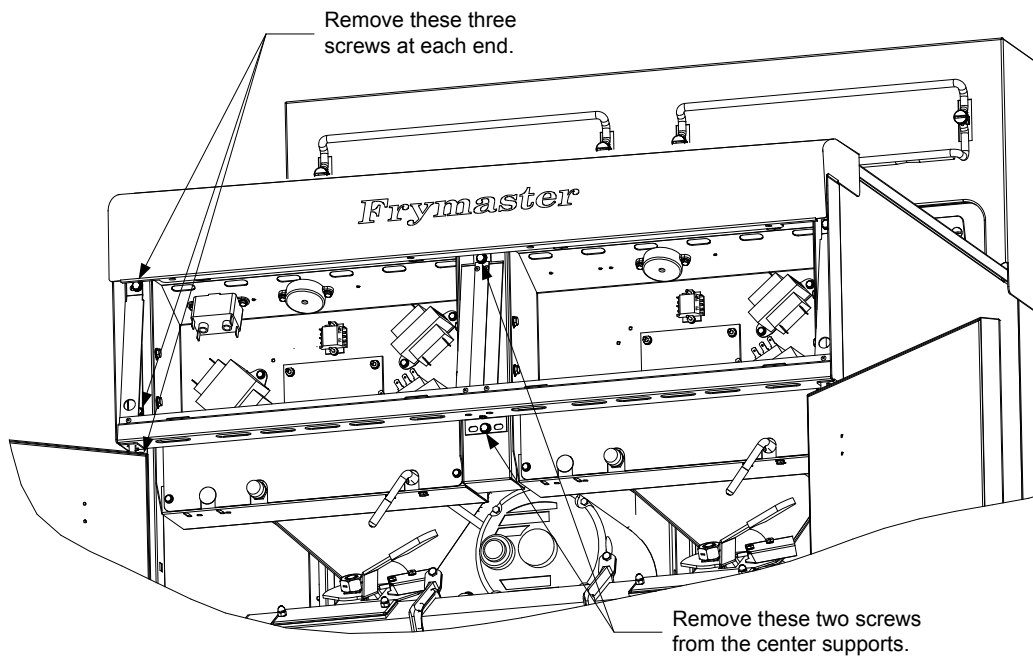

Removing the Control Panel Frame and Top Cap Assembly

5. Reconnect the wiring disconnected in Steps 2 and 3, referring to your notes and the wiring diagrams on the fryer door to ensure that the connections are properly made. Also, verify that no other wiring was disconnected accidentally during the replacement process.
6. Reverse steps 1-4 to complete the replacement and return the fryer to service.

7.4 Replacing a High-Limit Thermostat

1. Remove the filter pan and lid from the unit. Drain the frypots into a Shortening Disposal Unit (SDU) or other appropriate metal container.

⚠ DANGER
DO NOT drain more than one full frypot or two split frypots into the SDU at one time.

2. Disconnect the fryer from the electrical power supply and reposition it to gain access to the rear of the fryer.
3. Remove the four screws from both the left and right sides of the lower back panel.
4. Locate the high-limit that is being replaced and follow the two-black wires to the 12-pin connector C-6. Note where the leads are connected prior to removing them from the connector. Unplug the 12-pin connector C-6 and using a pin-pusher push the pins of the high-limit out of the connector.
5. Using a wrench, carefully remove the high-limit thermostat to be replaced.
6. Apply Loctite™ PST 567 or equivalent sealant to the threads of the replacement and install the high limit thermostat securely into the frypot.
7. Insert the leads into the 12-pin connector C-6 (see illustration below). For full-vat units or the left half of a dual-vat unit (as viewed from the rear of the fryer) the leads go into positions 1 and 2 of the connector. For the right half of a dual-vat unit (as viewed from the rear of the fryer), the leads go into positions 7 and 8. In either case, polarity does not matter.

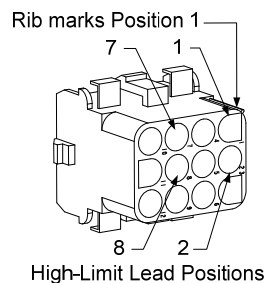

8. Reconnect the 12-pin connecting plug C-6. Use wire ties to secure any loose wires.
9. Reinstall the back panels, reposition the fryer under the exhaust hood, and reconnect it to the electrical power supply to return the fryer to service.

7.5 Replacing a Temperature Probe

1. Remove the filter pan and lid from the unit. Drain the frypots into a Shortening Disposal Unit (SDU) or other appropriate metal container.



DANGER

DO NOT drain more than one full frypot or two split frypots into the SDU at one time.

2. Disconnect the fryer from the electrical power supply and reposition it to gain access to the rear of the fryer.
3. Remove the four screws from both sides of the lower back panel. Then remove the two screws on both the left and right sides of the back of the tilt housing. Lift the tilt housing straight up to remove from the fryer.
4. Locate the wires of the temperature probe to be replaced. Note where the leads are connected prior to removing them from the connector. Unplug the 12-pin connector C-6 and using a pin-pusher push the pins of the temperature probe out of the connector.

5. Raise the element and remove the securing probe bracket and metal tie wraps that secure the probe to the element (see illustration on the following page).

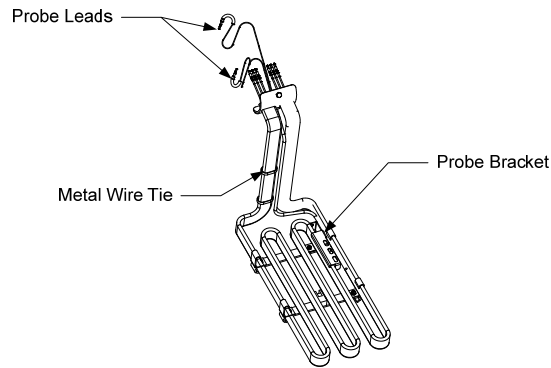

6. Gently pull on the temperature probe and grommet. Pulling the wires up the rear of the fryer and through the element tube assembly.
7. Insert the replacement temperature probe (wires first) into the tube assembly ensuring that the grommet is in place. Secure the probe to the elements using the bracket which was removed in Step 5 and the metal tie wraps which were included in the replacement kit.
8. Route the probe wires out of the tube assembly following the element wires down the back of the fryer through the Heyco bushings to the 12-pin connector C-6. Secure the wires to the sheathing with wire ties.
9. Insert the temperature probe leads into the 12-pin connector C-6 (see illustration below). For full-vat units or the right half of a dual-vat unit (as viewed from the rear of the fryer) the red, yellow or black lead goes into position 3 and the white lead into position 4 of the connector. For the left half of a dual-vat unit (as viewed from the rear of the fryer), the red, yellow or black lead goes into position 9 and the white lead into position 10.

NOTE: *Right* and *left* refer to the fryer as viewed from the rear.

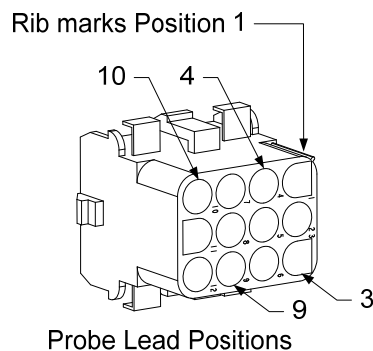

10. Secure any loose wires with wire ties making sure that the lead wires will not interfere with the movement of the springs. Rotate the elements up and down making sure that movement is not restricted and that the wires are not pinched.
11. Reinstall the tilt housing and back panels, reposition the fryer under the exhaust hood, and reconnect it to the electrical power supply to return the fryer to service.

7.6 Replacing a Heating Element

1. Perform steps 1-3 of section 7.5, *Replacing a Temperature Probe*.
2. On dual-vat fryers, and on full-vat fryers where the temperature probe is attached to the element being replaced, disconnect the wire harness containing the probe wiring. Using a pin pusher, disconnect the probe wires from the 12-pin connector C-6.
3. In the rear of the fryer directly behind the frypot disconnect the 6-pin connector for the left element (as viewed from the front of the fryer) or the 9-pin connector for the right element. Press in on the tabs on each side of the connector while pulling outward on the free end to extend the connector and release the element leads (see photo below). Pull the leads out of the connector and out of the wire sleeving.

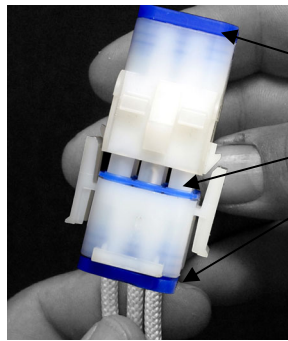

Note: Liquid resistant seals.

4. Raise the element to the full up position and support the elements.
5. Remove the hex head screws and nuts that secure the element to the tube assembly and pull the element out of the frypot.

NOTE: Full-vat elements consist of two dual-vat elements clamped together. For full-vat units, remove the element clamps before removing the nuts and screws that secure the element to the tube assembly.

6. If applicable, recover the probe bracket and probe from the element being replaced and install them on the replacement element, then install the replacement element in the frypot, securing it with the nuts and screws removed in Step 5 to the tube assembly ensuring the gasket is between the tube and element assembly.
7. Route the element leads through the element tube assembly and into the wire sleeving to prevent chafing. Ensure that the wire sleeving is routed back through the Heyco bushing keeping it clear from the lift springs. Also ensure that the wire sleeving extends into the tube assembly to protect the edge of the tube assembly from chafing the wires. Press the pins into the connector in accordance with the diagram below, and then close the connector to lock the leads in place.

NOTE: It is critical that the wires be routed through the sleeving to prevent chafing.

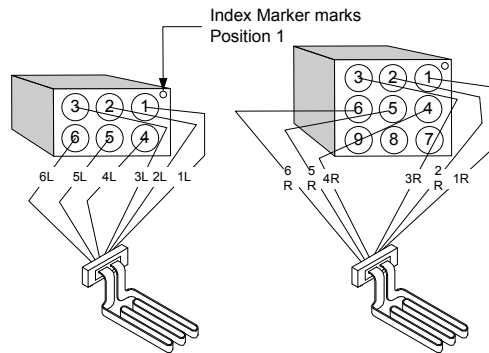

8. Reconnect the element connector that was removed from directly behind the frypot, ensuring that the latches lock.
9. Insert the temperature probe leads into the 12-pin wiring harness connector C-6 (see illustration below). For full-vat units or the right half of a dual-vat unit, the red lead goes into position 3 and the white into position 4. For the left half of a dual-vat unit, the red lead goes into position 9 and the white into position 10.

NOTE: *Right* and *left* refer to the fryer as viewed from the rear.

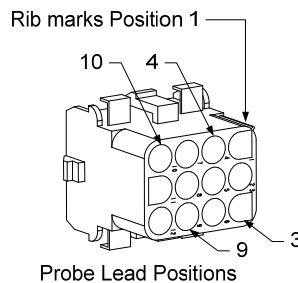

10. Reconnect the 12-pin connector C-6 of the wiring harness disconnected in Step 2.
11. Lower the element down onto the basket rack.
12. Reinstall the tilt housing and back panels, reposition the fryer under the exhaust hood, and reconnect it to the electrical power supply.

7.7 Replacing Contactor Box Components

1. If replacing a contactor box component above the built-in filter system, remove the filter pan and lid from the unit. Drain the frypots into a Shortening Disposal Unit (SDU) or other appropriate metal container. If replacing a contactor box component in a non-filter unit or a frypot that's not over the filter pan, drain the frypot above the box into a Shortening Disposal Unit (SDU) or other appropriate metal container.

⚠ DANGER

DO NOT drain more than one full frypot or two split frypots into the SDU at one time.

2. Disconnect the fryer from the electrical power supply.

3. Remove the two screws securing the cover of the contactor box. The contactor boxes above the filter pan are accessed by sliding under the fryer. They are located to the left and right above the guide rails (see photo below). The contactor boxes of non-filter units or frypots not over the filter pan are accessed by opening the fryer door directly under the affected frypot.

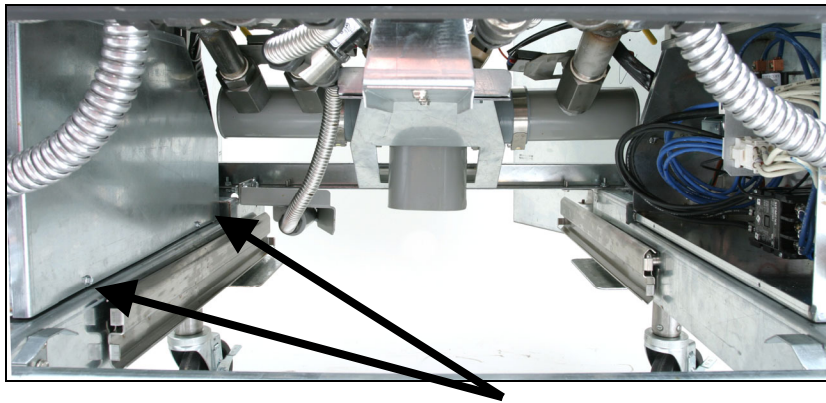

Remove two screws to access contactor box components above the filter pan.

4. The contactors and relays are held on by threaded pin studs so that only removal of the nut is required to replace the component.
5. After performing necessary service, reverse steps 1-4 to return the fryer to operation.

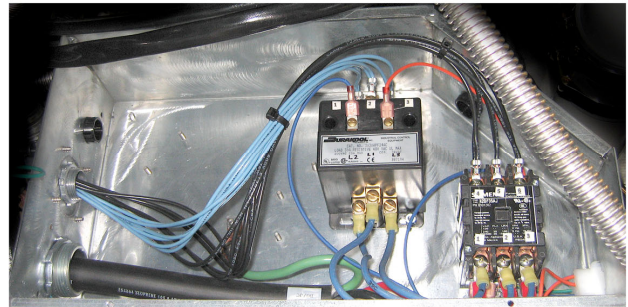
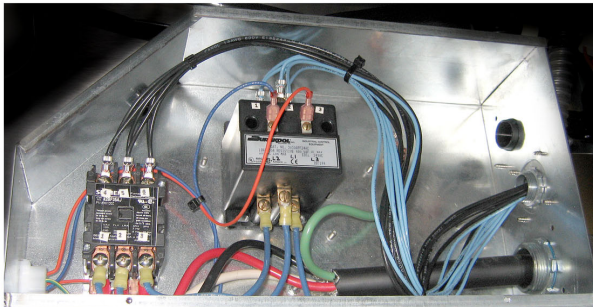

Left and right views of contactor box components.

7.8 Replacing a Frypot

1. Drain the frypot into the filter pan or, if replacing a frypot over the filter system, into a Shortening Disposal Unit (SDU) or other appropriate metal container. If replacing a frypot over the filter system, remove the filter pan and lid from the unit.

⚠ DANGER
DO NOT drain more than one full frypot or two split frypots into the SDU at one time.

2. Disconnect the fryer from the electrical power supply and reposition it to gain access to both the front and rear.
3. Slide the metal bezel up to release the bottom tabs, then slide the bezel down to disengage the upper tabs.

4. Remove the two screws from the upper corners of the control panels and allow them to swing down (as shown in photo on page 7-1).
5. Unplug the wiring harnesses and ground wires from the backs of the controllers. Remove the controllers by lifting them from the hinge slots in the control panel frame.
6. Remove the tilt housing and back panels from the fryer. The tilt housing must be removed first in order to remove the upper back panel.
7. To remove the tilt housing remove the hex head screws from the rear edge of the housing. The housing can be lifted straight up and off the fryer.
8. Remove the control panel by removing the screw in the center and the nuts on both sides.
9. Loosen the component boxes by removing the screws, which secure them in the cabinet.
10. Dismount the top cap by removing the nuts at each end that secure it to the cabinetry.
11. Remove the hex head screw that secures the front of the frypot to the cabinet cross brace.
12. Remove the top-connecting strip that covers the joint with the adjacent frypot.
13. Unscrew the Teflon vent/vacuum-breaker tube fitting, unscrew the nut located on the front of each section of drain tube, and remove the tube assembly from the fryer.
14. Remove the covers from the drain safety switch(es) and disconnect the switch wiring at the switch(es).
15. At the rear of the fryer, unplug the 12-pin connector C-6 and, using a pin pusher, disconnect the high-limit thermostat leads.
16. Disconnect the oil return flexline(s) at the frypot end(s).
17. Raise the elements to the “up” position and disconnect the element springs.
18. Remove the machine screws and nuts that secure the element tube assembly to the frypot. Carefully lift the element assembly from the frypot and secure it to the cross brace on the rear of the fryer with wire ties or tape.
19. Carefully lift the frypot from the fryer and place it upside down on a stable work surface.
20. Recover the drain valve(s), oil return flexline connection fitting(s), and high-limit thermostat(s) from the frypot. Clean the threads and apply Loctite™ PST 567 or equivalent sealant to the threads of the recovered parts and install them in the replacement frypot.
21. Carefully lower the replacement frypot into the fryer. Reinstall the hex head screw removed in step 7 to attach the frypot to the fryer.
22. Position the element tube assembly in the frypot and reinstall the machine screws and nuts removed in step 18.

23. Reconnect the oil return flexlines to the frypot, and replace aluminum tape, if necessary, to secure heater strips to the flexlines.
24. Insert the high-limit thermostat leads disconnected in step 15 (see illustration on page 7-3 for pin positions).
25. Reconnect the drain safety switch wiring to the switch(es) in accordance with the diagram below then reinstall the switch covers.

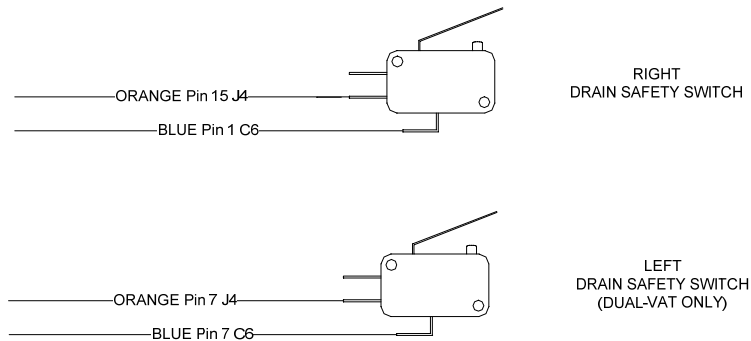

26. Reinstall the drain tube assembly.
27. Reinstall the top connecting strips, top cap, tilt housing and back panels.
28. Reinstall controllers in the control panel frame and reconnect the wiring harnesses and ground wires.
29. Reposition the fryer under the exhaust hood and reconnect it to the electrical power supply.

7.9 Built-in Filtration System Service Procedures

7.9.1 Filtration System Problem Resolution

One of the most common causes of filtration problems is placing the filter paper on the bottom of the filter pan rather than over the filter screen.

⚠ CAUTION

Ensure that filter screen is in place prior to filter paper placement and filter pump operation. Improper screen placement is the primary cause of filtration system malfunction.

Whenever the complaint is “the pump is running, but no oil is being filtered,” check the installation of the filter paper, and ensure that the correct size is being used. While you are checking the filter paper, verify that the O-ring on the bottom of the filter pan is present and in good condition. A missing or worn O-ring allows the pump to take in air and decreases its efficiency. Also, check for oil leaks on the floor each time a vat is drained.

If the pump motor overheats, the thermal overload will trip and the motor will not start until it is reset. If the pump motor does not start, press the red reset switch (button) located on the rear of the motor.

If the pump starts after resetting the thermal overload switch, then something is causing the motor to overheat. A major cause of overheating is when several frypots are filtered sequentially, overheating the pump and motor. Allow the pump motor to cool at least 30 minutes before resuming operation. Pump overheating can be caused by:

- Solidified shortening in the pan or filter lines, or
- Attempting to filter unheated oil or shortening (cold oil and shortening are more viscous, overloading the pump motor and causing it to overheat).

If the motor runs but the pump does not, there is a blockage in the pump. Incorrectly sized or installed paper/pads will allow food particles and sediment to pass through the filter pan and into the pump. When sediment enters the pump, the gears bind, causing the motor to overload, again tripping the thermal overload. Shortening that has solidified in the pump will also cause it to seize, with the same result.

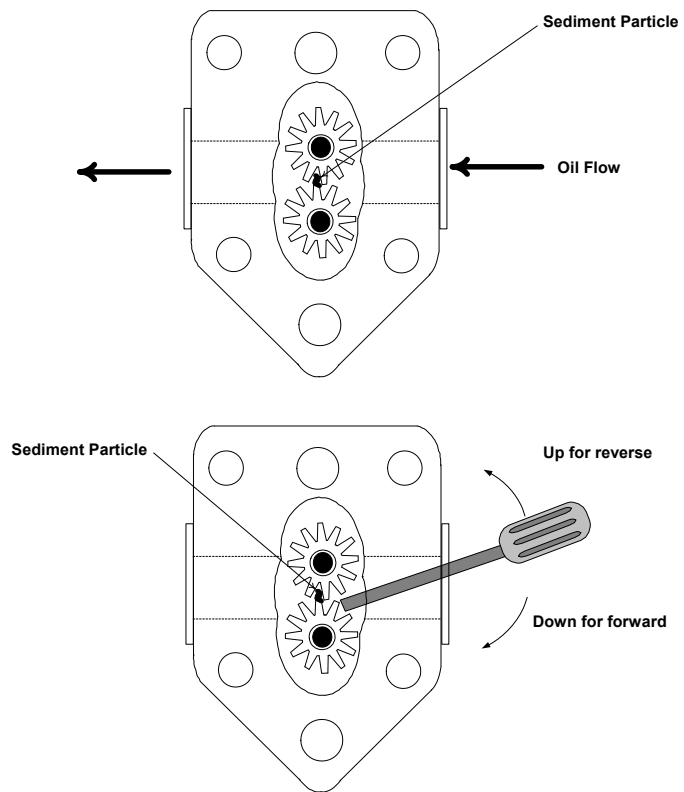

A pump seized by debris or hard shortening can usually be freed by manually moving the gears with a screwdriver or other instrument.

Disconnect power to the filter system, remove the input plumbing from the pump, and use a screwdriver to manually turn the gears.

- Turning the pump gears in reverse will release a hard particle and allow free movement of the gears.
- Turning the pump gears forward will push softer objects and solid shortening through the pump and allow free movement of the gears.

Incorrectly sized or installed paper/pads will also allow food particles and sediment to pass through and clog the suction tube on the bottom of the filter pan. Particles large enough to block the suction tube may indicate that the crumb tray is not being used. Pan blockage can also occur if shortening is left in the pan and allowed to solidify. Blockage removal can be accomplished by forcing the item out with an auger or drain snake. Compressed air or other pressurized gases should not be used to force out the blockage.

7.9.2 Replacing the Filter Motor, Filter Pump, and Related Components

1. Remove the filter pan and lid from the unit. Drain the frypots into a Shortening Disposal Unit (SDU) or other appropriate metal container.



DANGER

DO NOT drain more than one full frypot or two split frypots into the SDU at one time.

2. Disconnect the fryer from the electrical power supply and reposition it to gain access to both the front and rear.
3. Disconnect the two flexlines running to the oil-return manifold at the rear of the fryer as well as the pump suction flexline at the end of the filter pan connection (see photo below).

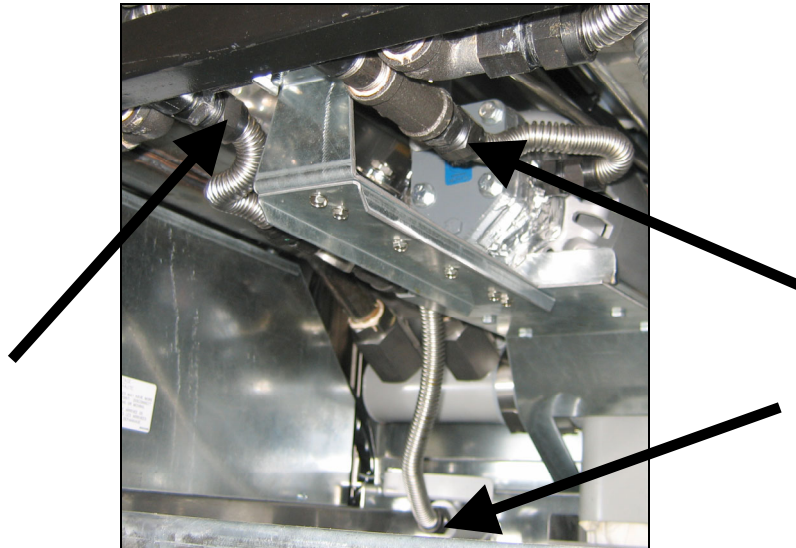

Disconnect flexlines indicated by the arrows.

4. Loosen the nut and bolt that secures the bridge to the oil-return manifold.
5. Remove the cover plate from the front of the motor and disconnect the motor wires.
6. Unplug the pump motor assembly 6-pin connector C-2 and, using a pin pusher, disconnect the vent vacuum-breaker solenoid (pins 2 and 5) that is attached to the oil return manifold.
7. Remove the two nuts and bolts that secure the front of the bridge to the cross brace and carefully slide the bridge rearward off the cross brace until its front end can be lowered to the floor. Undo the single nut holding it in place in back. Be careful not to let the rear of the bridge slip off the manifold at this point.
8. Get a good grip on the bridge, carefully pull it forward off the oil-return manifold, and lower the entire assembly to the floor. Once on the floor, pull the assembly out the front of the fryer.
9. When required service has been completed, reverse steps 6-12 to reinstall the bridge.

NOTE: The black motor wires go on the top terminal, the white on the bottom. The pump solenoid valve wires go in positions 1 and 4 of the 6-pin connector C-2; the vent vacuum-breaker solenoid valve wires go in positions 2 and 5; the red/black heater tape wires go into position 3 and the violet/white wires go into position 6 (see illustration on the following page).

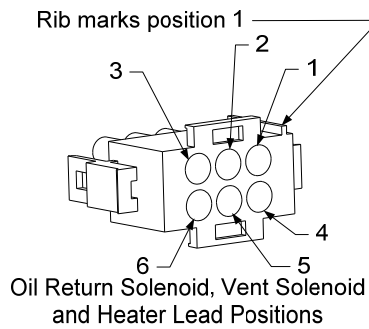

10. Reconnect the unit to the electrical power supply, and verify that the pump is functioning correctly (i.e., when a filter handle is placed in the ON position, the motor should start and there should be strong suction at the intake fitting and outflow at the rear flush port.)
11. When proper operation has been verified, reinstall the back panels and the filter pan and lid.
12. Reposition the fryer under the exhaust hood and reconnect it to the electrical power supply to return the fryer to service.

7.9.3 Replacing the Filter Transformer or Filter Relay

Remove the left controller from the fryer to expose the interior of the left component box. The filter transformer and relay are located as shown in the illustration below.

NOTE: The right component box is identical to the left except that the filter transformer and relay are not present.

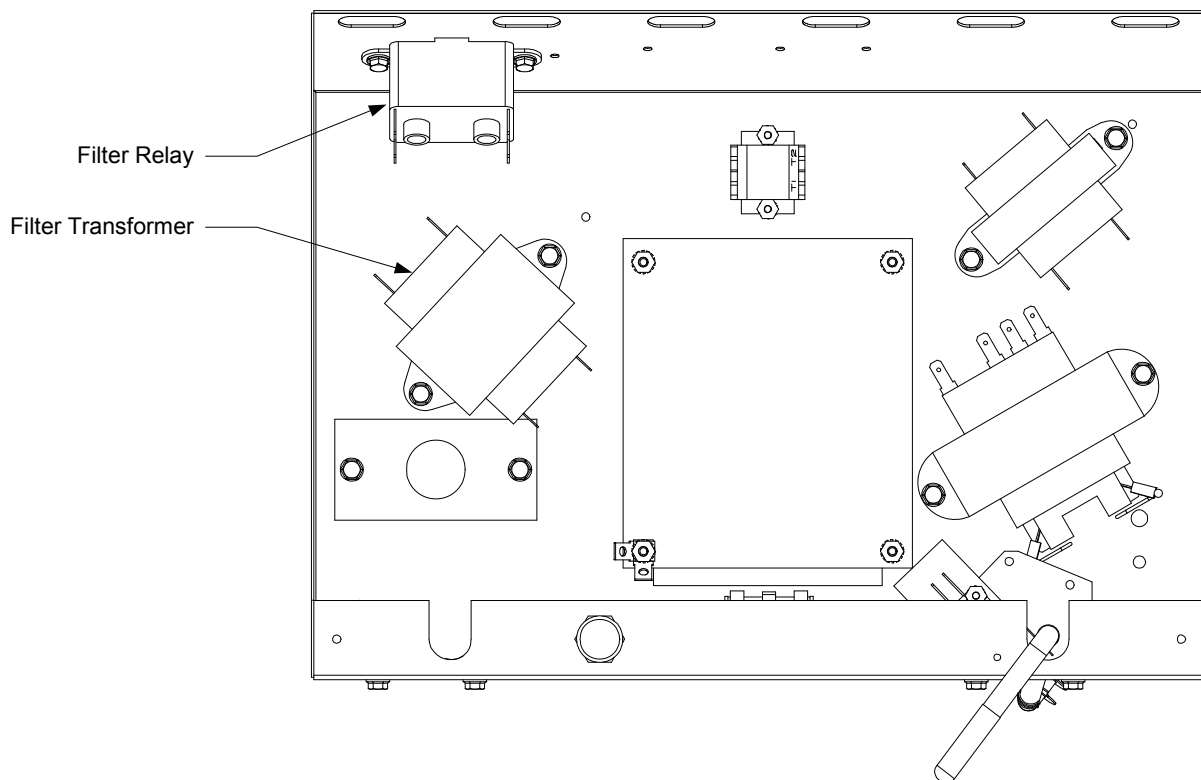

7.10 Interface Board Diagnostic Chart

The following diagram and charts provide ten quick system checks that can be performed using only a multimeter.

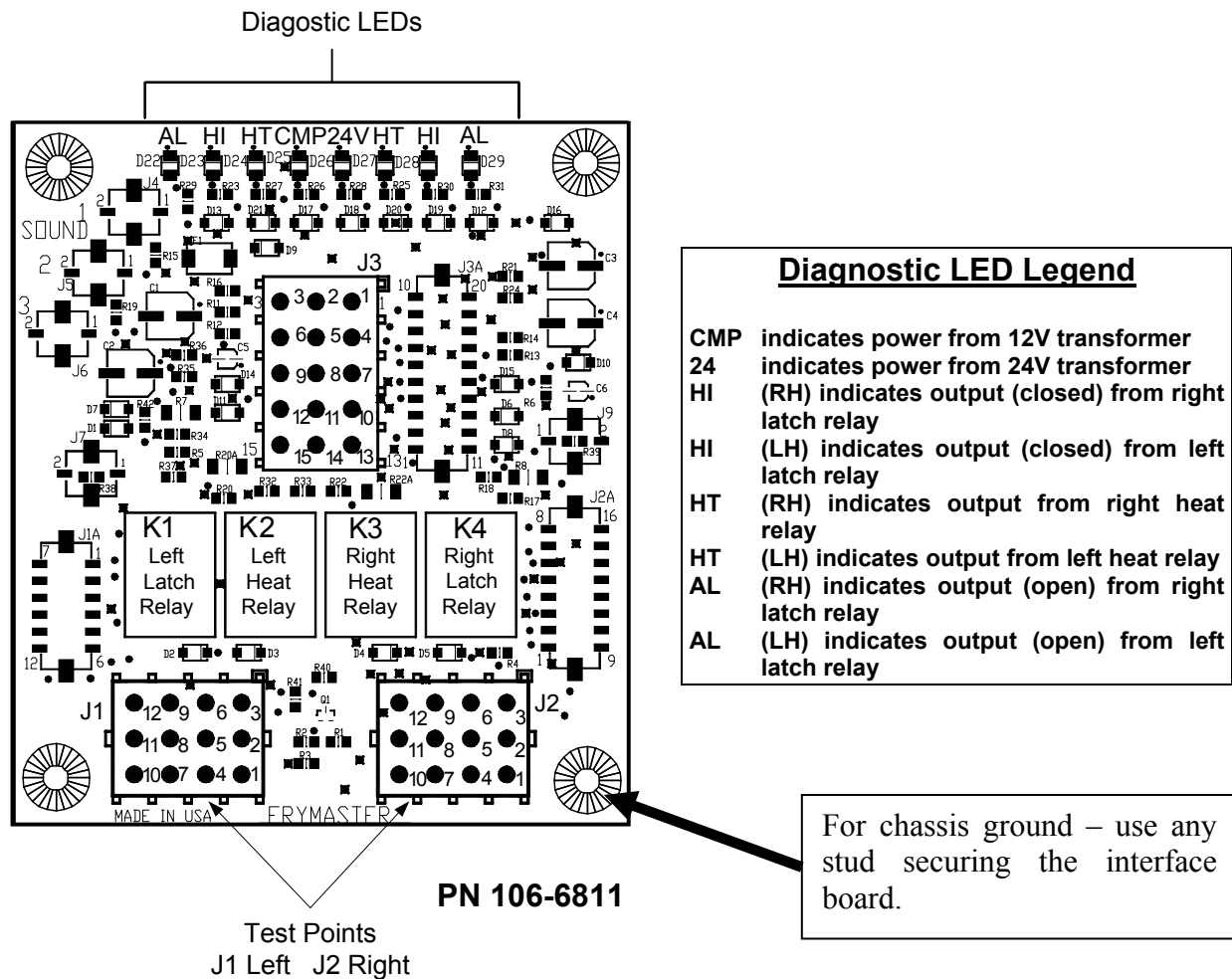

NOTE – When testing the test points on J1 and J2 test use the illustration above disregarding any silkscreened numbers on the board depicting the location of Pin 1. Pin 1 is located in the bottom right corner of Both J1 and J2. These test points are ONLY for RE Series boards with J1 and J2 plugs on the front of the board.

Meter Setting	Test	Pin	Pin	Results
12 VAC Power	50 VAC Scale	3 of J2	1 of J2	12-16 VAC
24 VAC Power	50 VAC Scale	2 of J2	Chassis Ground	24-30 VAC
*Probe Resistance (RH)	R X 1000 OHMS	11 of J2	10 of J2	See Chart
*Probe Resistance (LH)	R X 1000 OHMS	1 of J1	2 of J1	See Chart
High-Limit Continuity (RH)	R X 1 OHMS	9 of J2	6 of J2	0 - OHMS
High-Limit Continuity (LH)	R X 1 OHMS	6 of J1	9 of J1	0 - OHMS
Latch Contactor Coil (RH)	R X 1 OHMS	8 of J2	Chassis Ground	3-10 OHMS
Latch Contactor Coil (LH)	R X 1 OHMS	5 of J1	Chassis Ground	3-10 OHMS
Heat Contactor Coil (RH)	R X 1 OHMS	7 of J2	Chassis Ground	18-25 OHMS
Heat Contactor Coil (LH)	R X 1 OHMS	4 of J1	Chassis Ground	18-25 OHMS

* Disconnect 15-Pin harness from the computer/controller before testing the probe circuit.

7.11 Probe Resistance Chart

<h3 style="text-align: center;">Probe Resistance Chart</h3> <p style="text-align: center;"><i>For use with fryers manufactured with Minco Thermistor probes only.</i></p>																	
F	OHMS	C	F	OHMS	C	F	OHMS	C	F	OHMS	C	F	OHMS	C			
60	1059	16	130	1204	54	200	1350	93	270	1493	132	340	1634	171			
65	1070	18	135	1216	57	205	1361	96	275	1503	135	345	1644	174			
70	1080	21	140	1226	60	210	1371	99	280	1514	138	350	1654	177			
75	1091	24	145	1237	63	215	1381	102	285	1524	141	355	1664	179			
80	1101	27	150	1247	66	220	1391	104	290	1534	143	360	1674	182			
85	1112	29	155	1258	68	225	1402	107	295	1544	146	365	1684	185			
90	1122	32	160	1268	71	230	1412	110	300	1554	149	370	1694	188			
95	1133	35	165	1278	74	235	1422	113	305	1564	152	375	1704	191			
100	1143	38	170	1289	77	240	1432	116	310	1574	154	380	1714	193			
105	1154	41	175	1299	79	245	1442	118	315	1584	157	385	1724	196			
110	1164	43	180	1309	82	250	1453	121	320	1594	160	390	1734	199			
115	1174	46	185	1320	85	255	1463	124	325	1604	163	395	1744	202			
120	1185	49	190	1330	88	260	1473	127	330	1614	166	400	1754	204			
125	1195	52	195	1340	91	265	1483	129	335	1624	168	405	1764	207			

7.12 Wiring Diagram, System

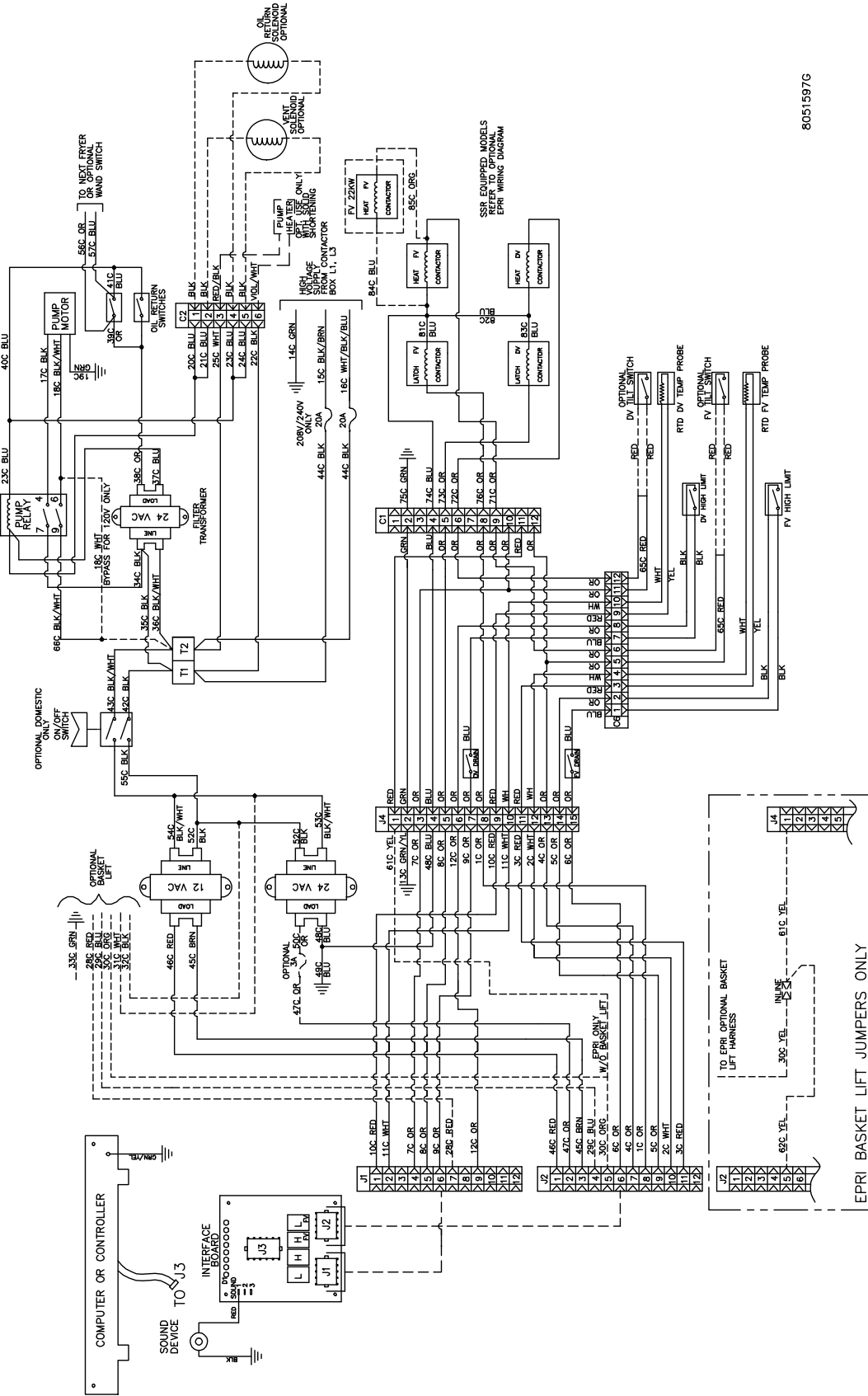

8051597G

7.13 Wiring Diagram, Contactor Box

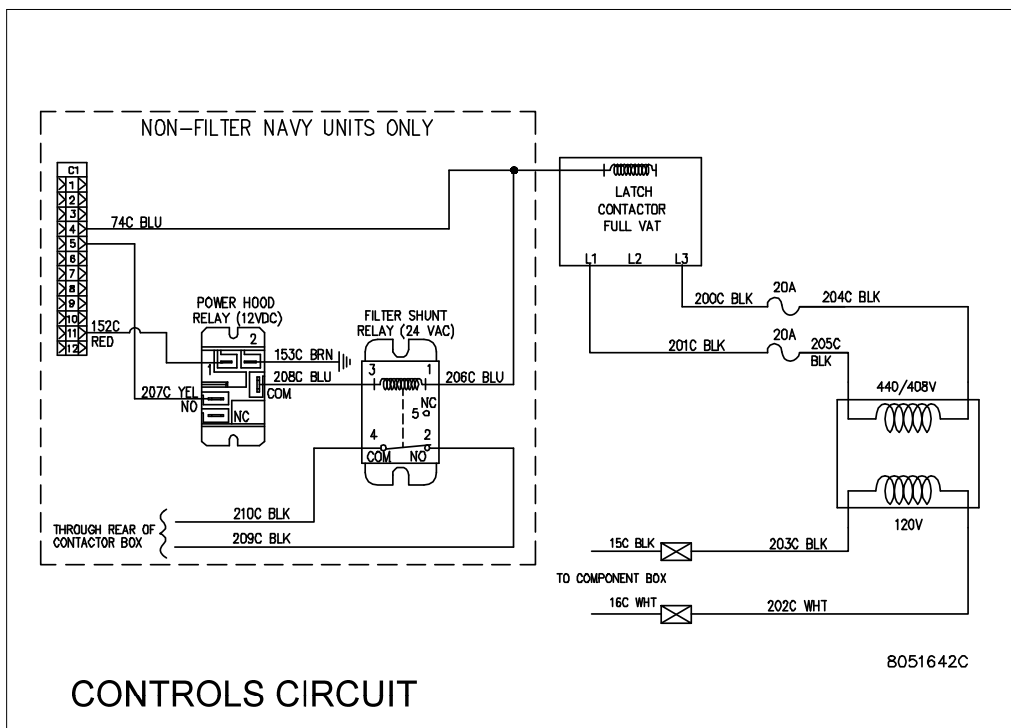
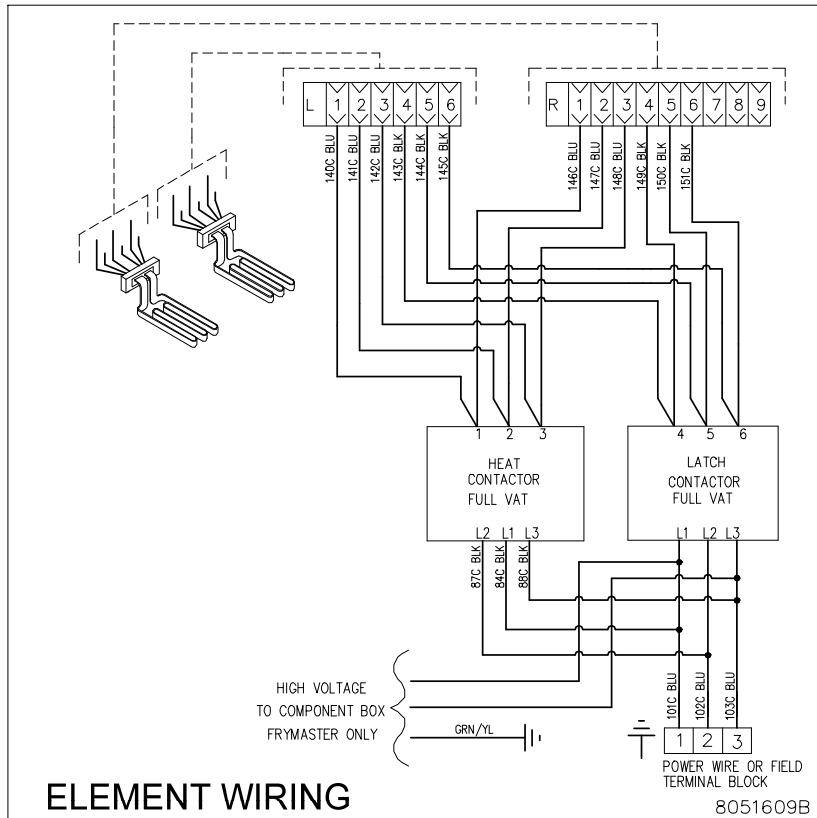

7.13 Wiring Diagram, Contactor Box cont.

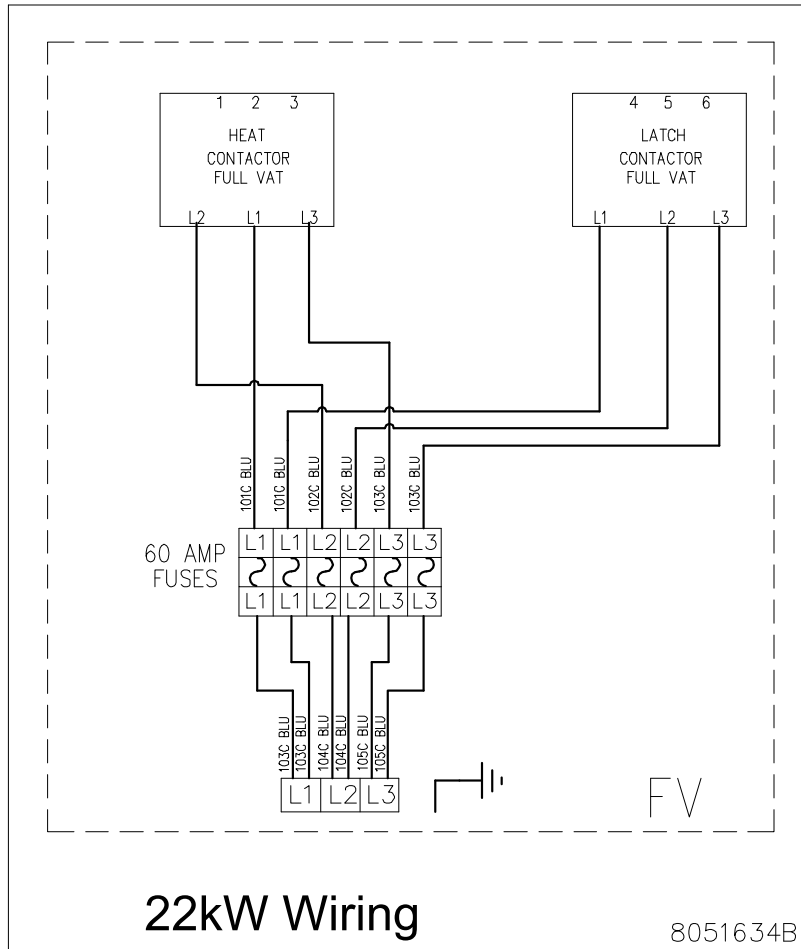

7.14 Wiring Diagram, Wiring Harness

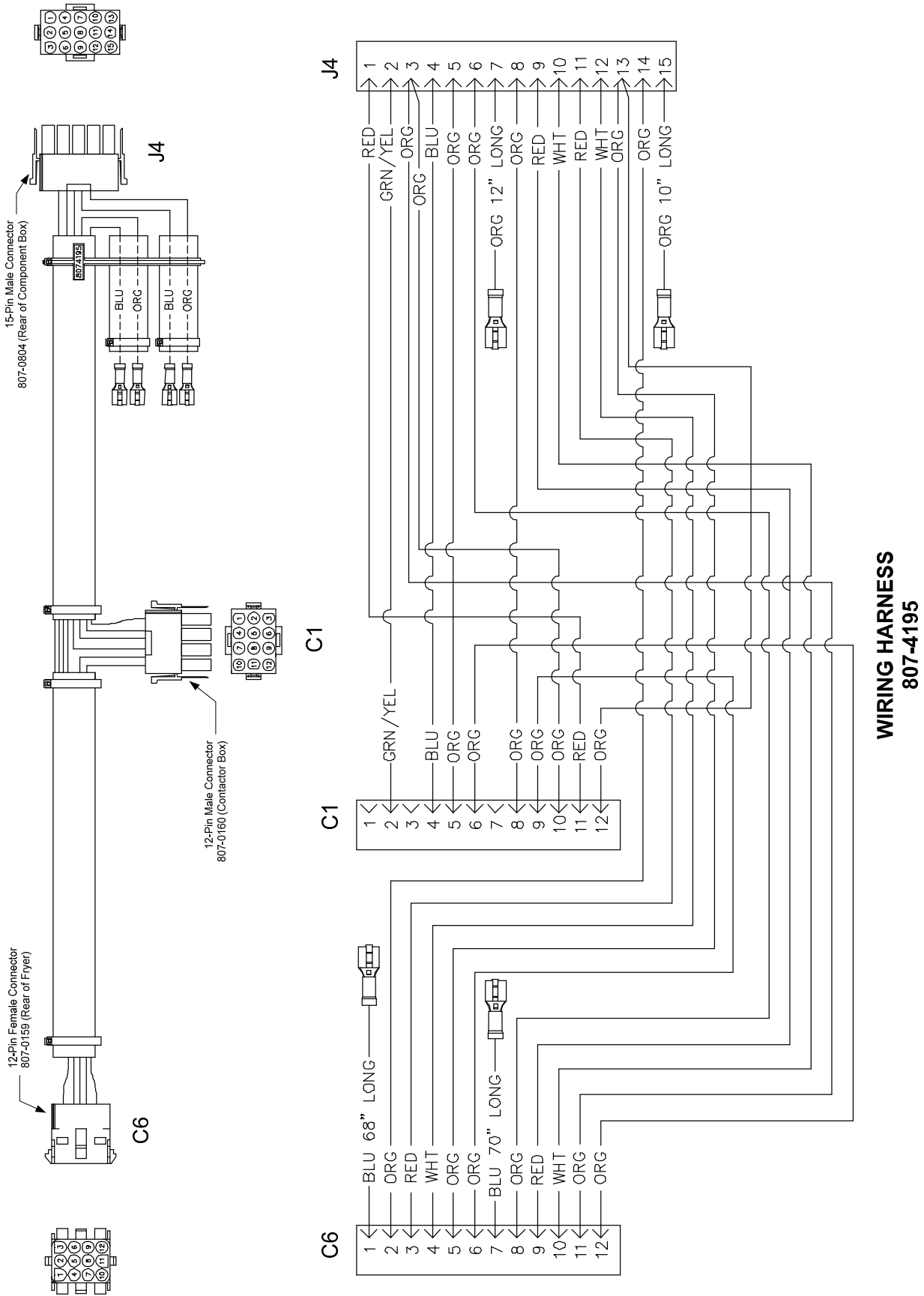

7.15 Components Description of Operation

- A. **Drain solenoid -** When the return valve is opened, a microswitch activates and supplies 24V to the pump relay and solenoids.
- B. **Vacuum release solenoid -** When the return valve is closed, it de-energizes the 24V to the pump relay and solenoids releasing the vacuum.
- C. **Full-vat oil return switch -** When the return valve is open, the 24V circuit is closed and it activates the pump relay and drain solenoid.
- D. **Dual-vat oil return switch -** When the return valve is open, the 24V circuit is closed and it activates the pump relay and drain solenoid.
- E. **Optional waste oil pump switch -** The drain valves and oil return valves are closed. When the oil waste discharge valve is opened, the 24V circuit is closed, it activates the pump relay and drain solenoid.
- F. **Safety interlock switch -** The interlock switch is in series with the high-limit. It is actuated when the drain valve opens, which opens the latch circuit which drops out the 12V circuit on the interface board. This removes power from the latching contactor which opens and de-energizes the heating elements.

NAVY (NON-US) SURFACE SHIP ELECTRIC FRYERS

CHAPTER 8: PARTS LIST

8.1 Accessories

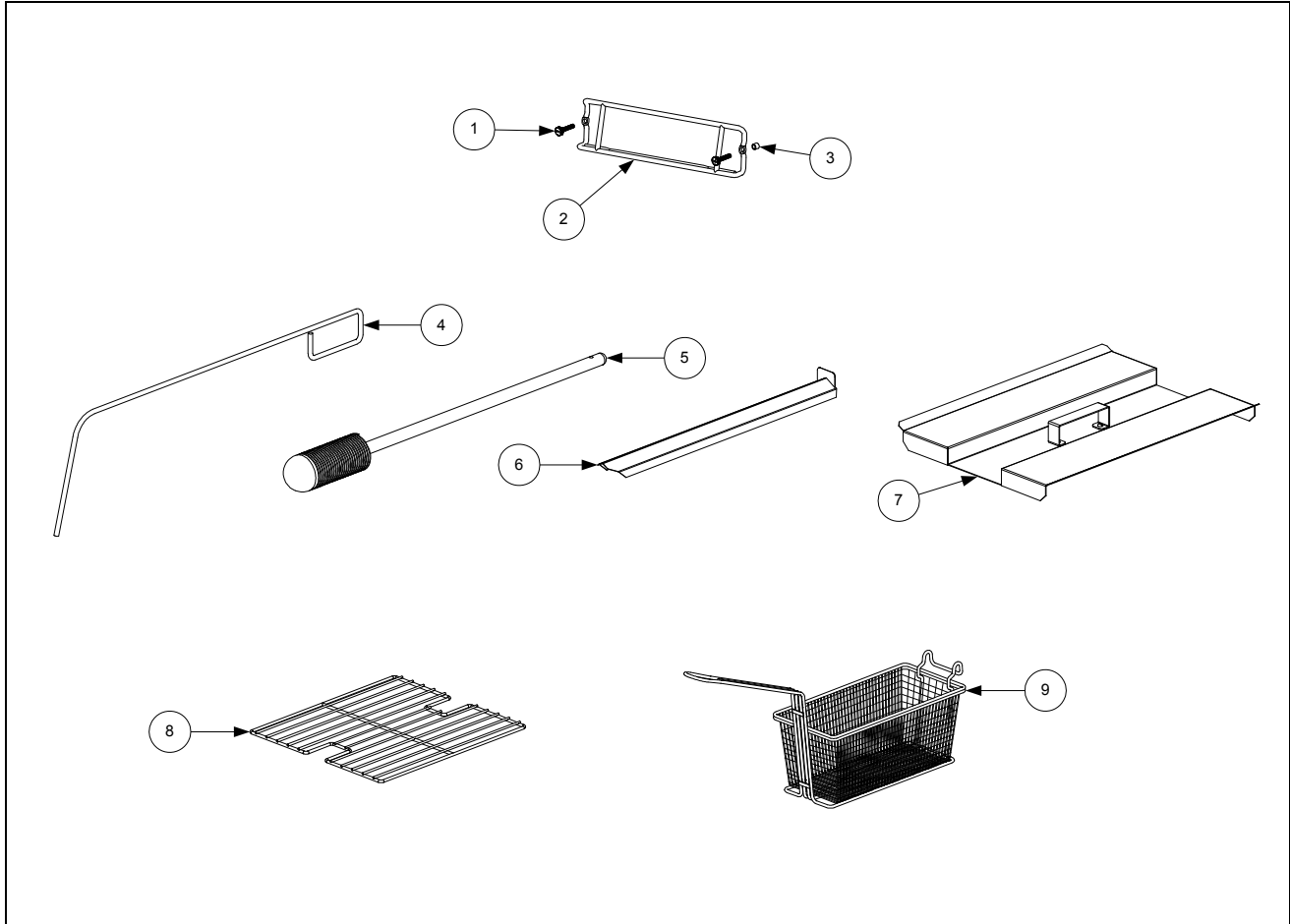

ITEM	PART #	COMPONENT
1	809-0171	Thumbscrew, 1/4 -20 X 1 3/8-inch
2	810-2793	Hanger, Wireform Basket
3	809-0921	Spacer, Basket Hanger
4	803-0197	Cleanout Rod, 27-inch
5	803-0209	Brush, Frypot
6	823-6009	Connecting Strip, Frypot
7	823-9414	Cover, Full-Vat Frypot
8	803-0132	Rack, Full-Vat Basket Support
9	803-0271	Basket, Twin
*	812-1226SP	Drain Nipple 1/4-inch Painted
*	823-2109	Drain Pan, Military
*	803-0002	Powder, Filter (80-8oz. Applications)
*	803-0170	Paper, Filter (100-Sheet Pack)

* Not illustrated.

8.2 Cabinetry

8.2.1 Backs, Control Panels, Doors, Handles, Sides, Tilt Housings & Top Caps

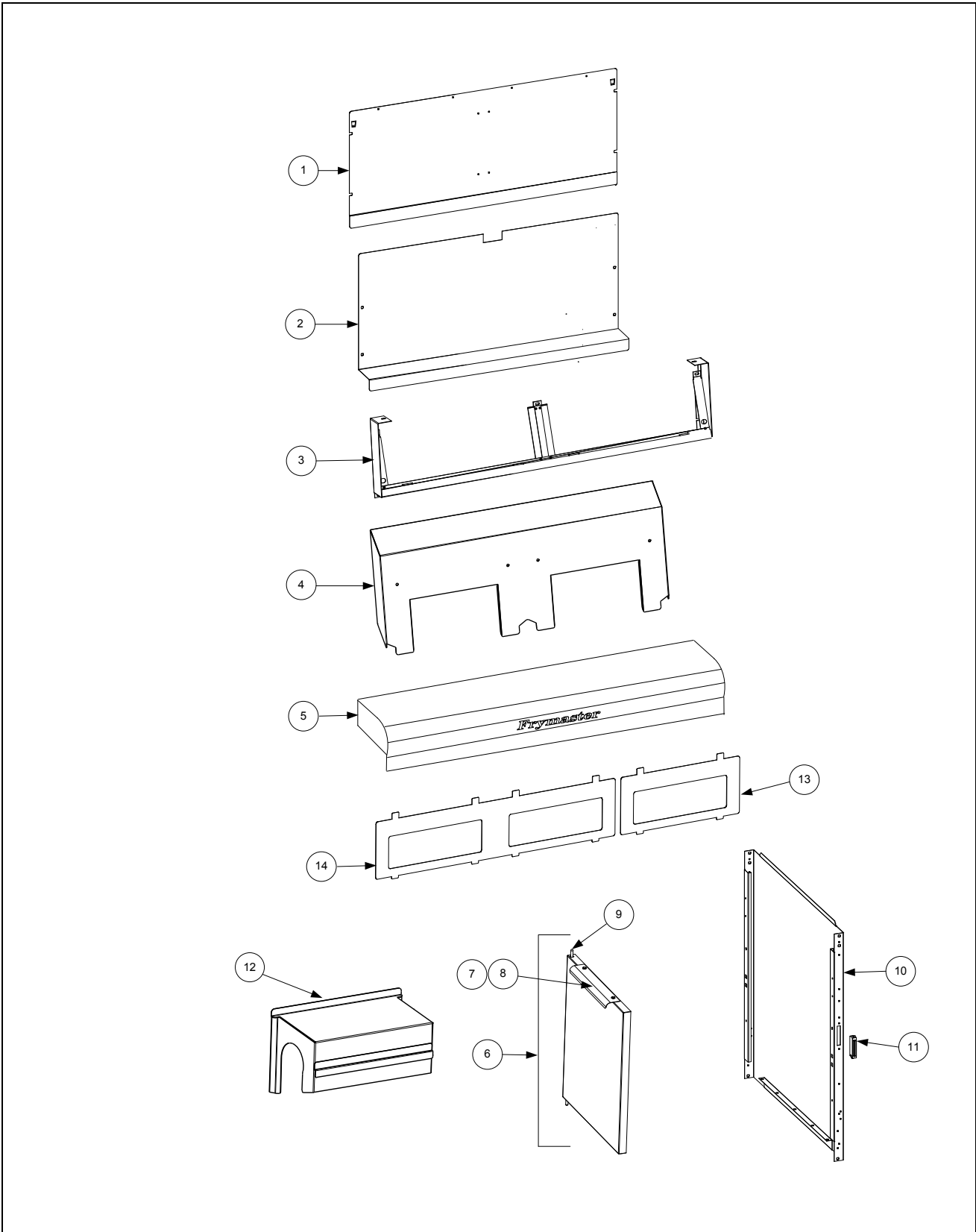

**8.2.1 Backs, Control Panels, Doors, Handles, Sides, Tilt Housings & Top Caps
(cont.)**

ITEM	PART #	COMPONENT
1	230-0675	Back Panel, Upper - Single
	230-0676	Two Station Fryer
	230-0677	Three Station Fryer
	230-0546	Four Station Fryer
2	230-0672	Back Panel, Center - Single
	230-0673	Two Station Fryer
	230-0674	Three Station Fryer
	230-0500	Four Station Fryer
3	106-5016	Frame, Control Panel - Single
	106-5221	Two Station Fryer
	106-5018	Three Station Fryer
	106-7533	Four Station Fryer
4	823-5567	Tilt Housing - Single
	823-5484	Two Station Fryer
	824-5493	Three Station Fryer
	823-6054	Four Station Fryer
5	106-5195	Top Cap - Single
	106-5196	Two Station Fryer
	106-5197	Three Station Fryer
	106-7531	Four Station Fryer
*	200-9614	Heat Shield - Single
	200-9610	Two/Four Station Fryer
	200-9611	Three Station Fryer
6	106-4979	Door Assembly - Single (includes items below plus 210-9214)
*	824-1516	Door, Universal Single
*	210-9215	Liner, Door Universal Single
*	809-0500	Screw, #10 – ½ Hex TR HD SS
*	826-1343	Spring, Door Pin Hinge (Pkg. of 10)
*	210-9188	Hinge, Door Single
*	106-4769	Door, Left or Right (Left shown – move handle to opposite side for Right)
		Two and Three Station Fryers
7	809-0266	Screw, #10 X ½-inch Phillips Truss Head
8	210-9214	Handle, Door (May differ from illustration shown)
9	106-0554	Pin Assembly, Door
*	826-1343	Spring, Door Pin Hinge (Pkg. of 10)
10	231-1558	Side, Cabinet Left, Single
	231-0326	Two or Three Station
	232-1558	Side, Cabinet Right, Single
	232-0326	Two or Three Station
11	810-1105	Magnet, Door
*	809-0123	Screw, #10 –3/4 Truss Slotted Head
*	826-1376	Nut KEPS 10-32 HX ZP (Pkg. of 10)
*	809-0970	Retaining Ring – Door Hinge Pin
*		Handle (Grab Rail) – (For handle end use 910-0915)
	823-0839	Single Station Fryer
	823-2908	Two Station Fryer
	823-4585	Three Station Fryer
	823-6049	Four Station Fryer
12	823-5440	Cove, Element Tilt Housing
13	230-2191	Bezel, One-Controller
14	230-2097	Bezel, Two/Four-Controller
	230-2193	Bezel, Three-Controller

*Not illustrated.

8.2.2 Cabinets, Bases, Braces, and Associated Parts

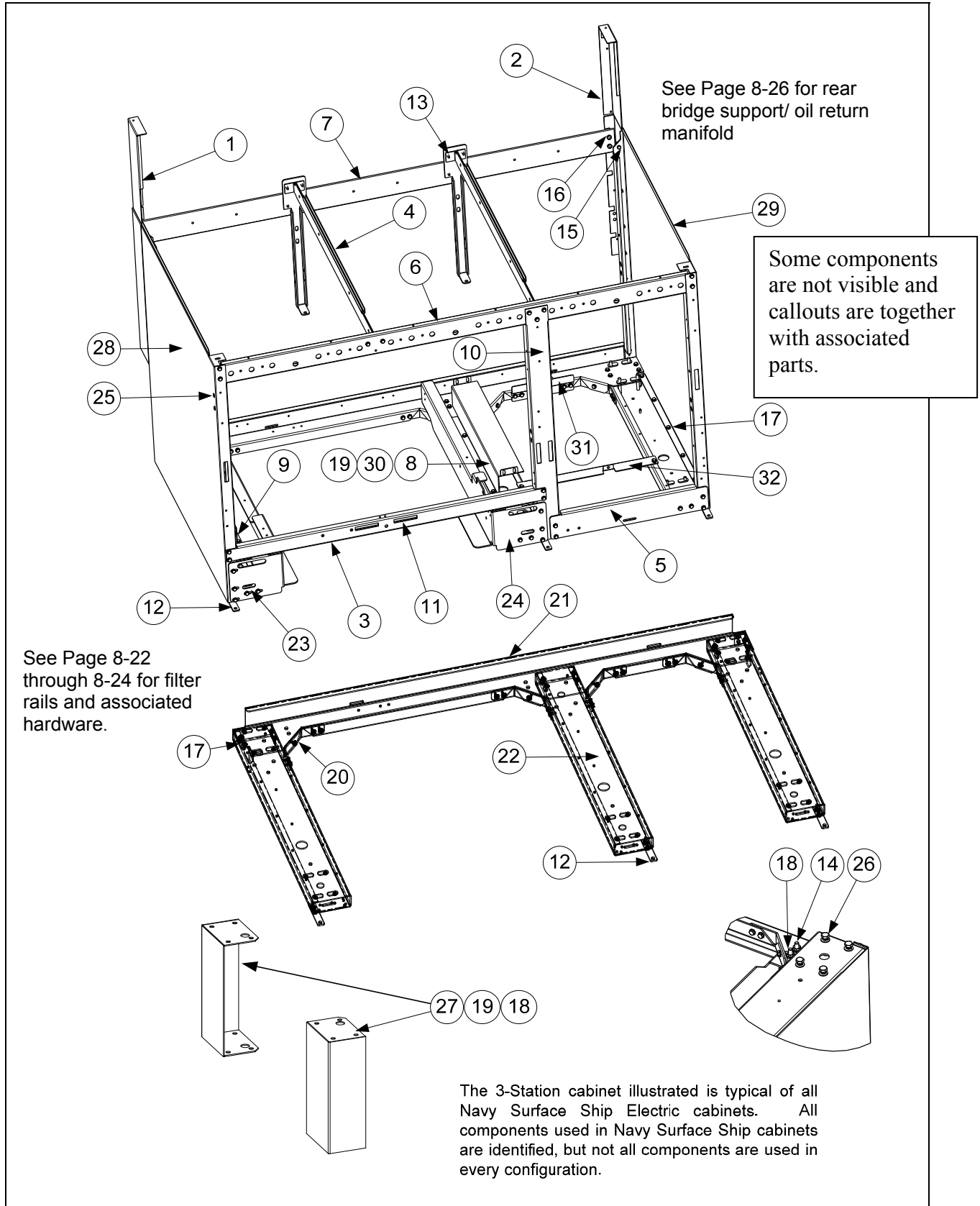

8.2.2 Cabinet Bases, Braces, and Associated Parts (cont.)

ITEM	PART #	COMPONENT
1	106-3828	Upright Assembly, Left
2	106-3829	Upright Assembly, Right
3	200-1651	Support, Cross Cabinet
4	200-1659	Divider, Cabinet
5	200-2293	Brace, Lower Front
6		Brace, Front Horizontal
	200-7036	Single-Station Fryer
	200-7037	Two-Station Fryer
	200-7038	Three-Station Fryer
	200-7039	Four-Station Fryer
7		Brace, Rear Horizontal
	200-5356	Single-Station Fryer
	200-2284	Two-Station Fryer
	200-2295	Three-Station Fryer
	200-2725	Four-Station Fryer
8	222-0610	Bracket, Right Hand Mounting
9	221-0610	Bracket, Left Hand Mounting
10	200-4424	Post, Door
11	810-2346	Magnet, Door
12	210-6862	Hinge, Door
13	824-1488	Bracket, Rear Support
14	826-1389	Bolt, 1/4-20 X 3/4-inch Hex Head (Pkg. of 10)
15	826-1330	Screw, 10-32 X 3/8-inch Slotted (Pkg. of 25, used to attach contactor box)
16	826-1376	Nut, 10-32 Keps Hex (Pkg. of 10)
17	826-1374	Screw, #10 X 1/2-inch Hex Washer Head (Primary cabinet screw Qty 25)
18	809-0417	Nut, 1/4-20 Hex Flange (used with item #22)
19	809-0429	Bolt, 1/4-20 X 2-inch Hex Head
20	200-5417	Brace, Rear Channel Corner
21		Channel, Base Rear
	823-5589	Single-Station Fryer (<i>106-4901 Single Base Non-Filter Assembly</i>)
	823-4558	Two-Station Fryer (<i>106-2744 - Double Base Assembly</i>)
	823-4560	Three-Station Fryer (<i>106-2745 - Triple Base Assembly</i>)
	823-4561	Four-Station Fryer (<i>106-2746 - Quad Base Assembly</i>)
22	824-1131	Channel, Base Side
23	200-4408	Support, Left Filter Pan
24	200-4409	Support, Right Filter Pan)
25	809-0079	Nutsert, 1/4" - 20
26	809-0191	Washer, 1/4" Lockspring
27	823-4386	Leg, Navy Shipboard (Mounts with Items 18 and 19)
28	231-0349	Side, LH Cabinet
29	232-0349	Side, RH Cabinet
30	809-0190	Washer, Flat 0.625"x 0.275"x 40 SS
31	220-1095	Support, Rear Contactor Box (<i>use 220-1192 for Singles</i>)
32	220-1093	Support, Front Contactor Box (<i>use 220-1193 for Singles</i>)
*	823-4584	Bar, Filter Pan Lock

* Not illustrated.

8.3 Drain System Components

8.3.1 Drain Tube Sections and Associated Parts

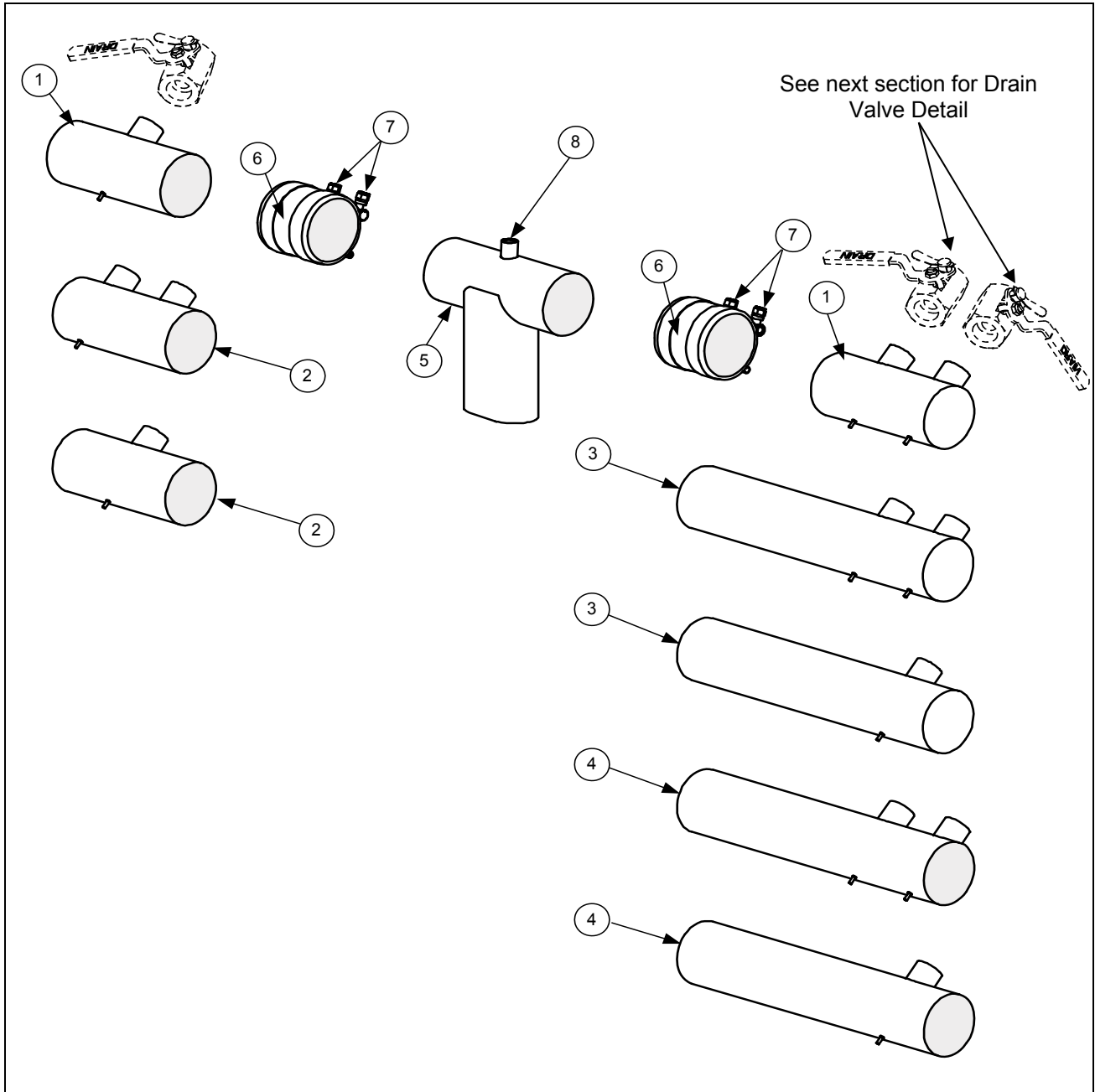

8.3.1 Drain Tube Section and Associated Parts (cont.)

ITEM	PART#	COMPONENT
1		Drain Tube, Left/Right End Short
	823-4625	Full-Vat 3"
	823-4624	Dual-Vat 3"
2		Drain Tube, Left/Right Open Short
	823-4643	Full-Vat 3"
	823-4642	Dual-Vat 3"
3		Drain Tube, Right End Long
	823-4639	Full-Vat 3"
	823-4638	Dual-Vat 3"
4		Drain Tube, Left/Right Open Long
	823-4641	Full-Vat 3"
	823-4640	Dual-Vat 3"
5	823-4892	Drain Outlet Center Dump
6	816-0625	Sleeve 3"
7	809-0969	Clamp, 3" T-Bolt
8	810-2492	Fitting, Quick-Connect Straight (receives Teflon vent tube)
*	KIT6033	Kit, Round Drain Clamp (2 or Item 7 and 1 of Item 6)
*	811-1071	Tube, Teflon Vent 1/4-inch OD (sold by the foot)

* Not illustrated.

8.3.2 Drain Valve Assembly and Assoc. Parts (Units with Built-In Filtration)

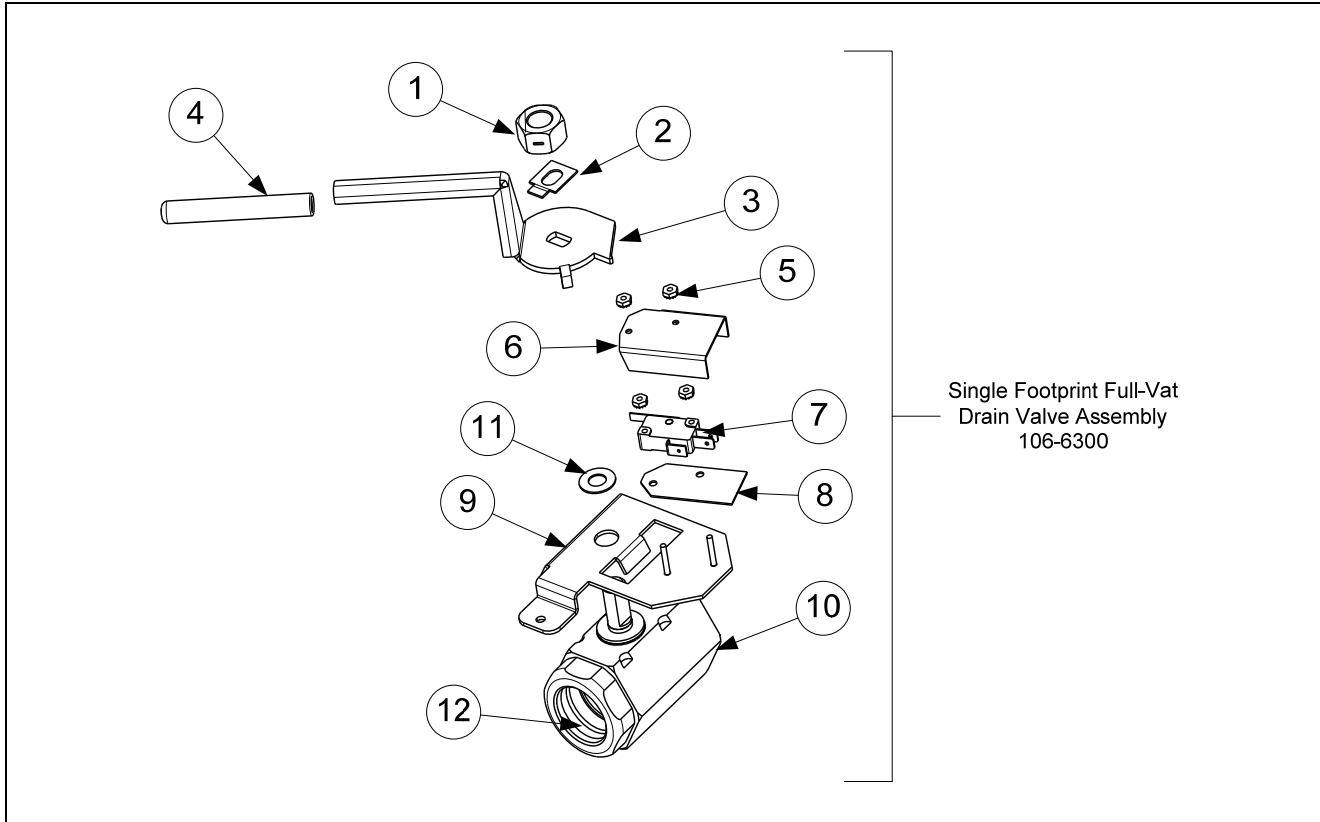

ITEM	PART #	COMPONENT
1	809-0540	Nut, 1/2-13 2-Way Hex Lock
2	900-2936	Retainer, Full-Vat Nut Drain Valve
3	824-1602	Handle, Full-Vat Drain Valve
4	816-0639	Cap, Red Handle
5	809-0237	Nut, 4-40 Keps Hex
6	901-2348	Cover, Dual Vat Drain Safety Switch
7	807-2103	Microswitch, CE Straight Lever
8	816-0220	Insulation, Drain Safety Switch
9	806-8137SP	Bracket Assembly, Full-Vat Drain Safety Switch
	106-5391	Bracket Assembly, Full-Vat Drain Safety Switch Single Footprint Only
10	810-1018	Valve, 1.25-inch Full-Vat Drain Single Footprint Only
11	810-1165	Washer, Teflon
12	816-0135PK	O-Ring, Round Drain (Qty. 4)

8.3.2 Drain Valve Assembly and Assoc. Parts cont. (Units with Built-In Filtration)

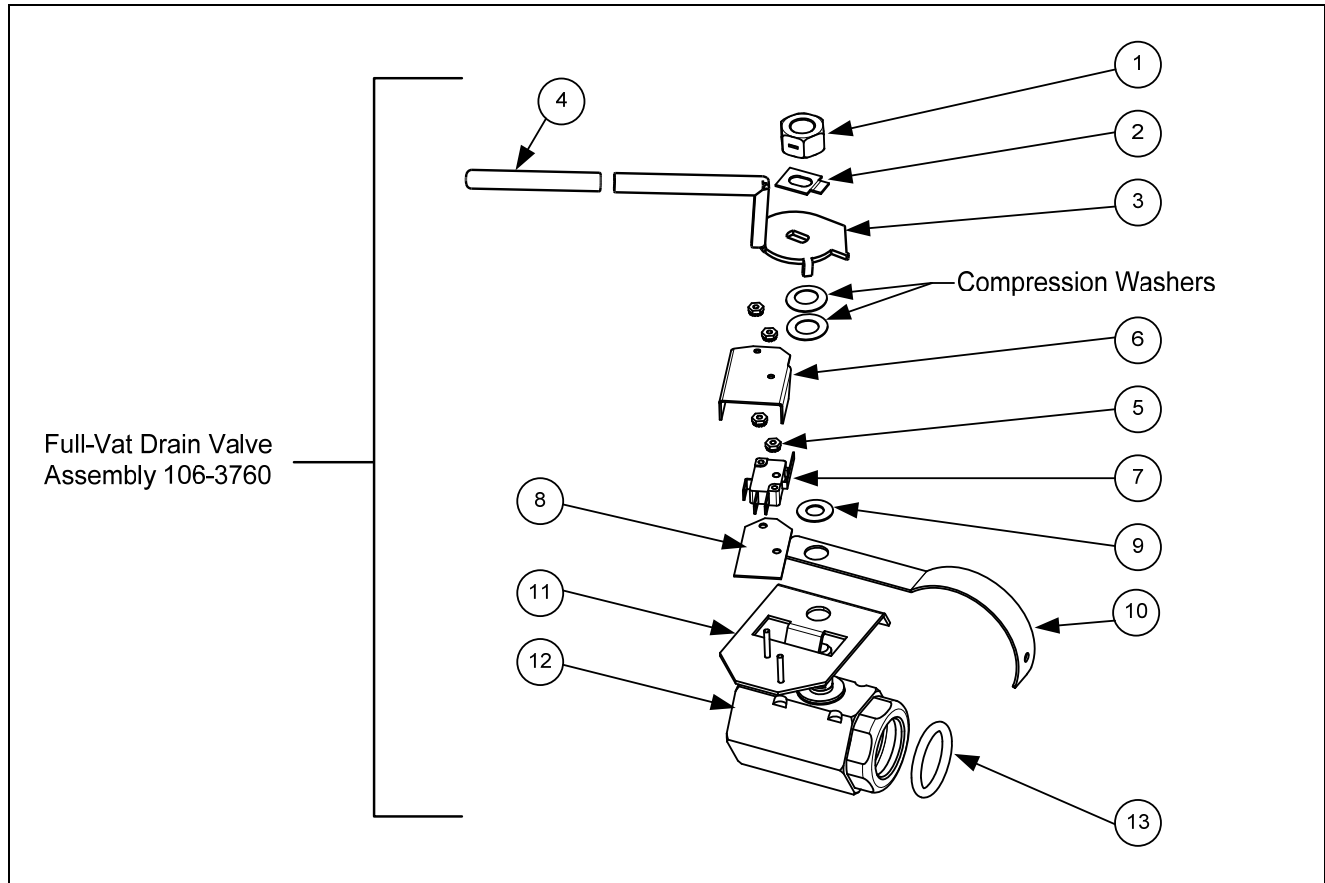

ITEM	PART#	COMPONENT
1	809-0540	Nut, 1/2-13 2-Way Hex Lock
2	900-2936	Retainer, Full-Vat Drain Valve Nut
3	824-1602	Handle, Full-Vat Drain Valve
4	816-0639	Cap, Red Handle
5	809-0237	Nut, 4-40 Keps Hex
6	901-2348	Cover, Dual Vat Drain Safety Switch
7	807-2103	Microswitch, CE Straight Lever
8	816-0220	Insulation, Drain Safety Switch
9	810-1165	Washer, Teflon Drain Valve
10	200-6496	Support, 3" Drain
11	806-8137	Bracket Assembly, Full-Vat Drain Safety Switch
12	810-1018	Valve, 1.25-inch Full-Vat Drain
13	816-0135PK	Round Drain O-Ring (Qty. 4)

8.3.2 Drain Valve Assembly and Assoc. Parts cont. (Units with Built-In Filtration)

Dual-Vat Drain Valve
Right Assembly
106-5606 /
106-6302 Single FP

Some components may
differ slightly from
illustration.

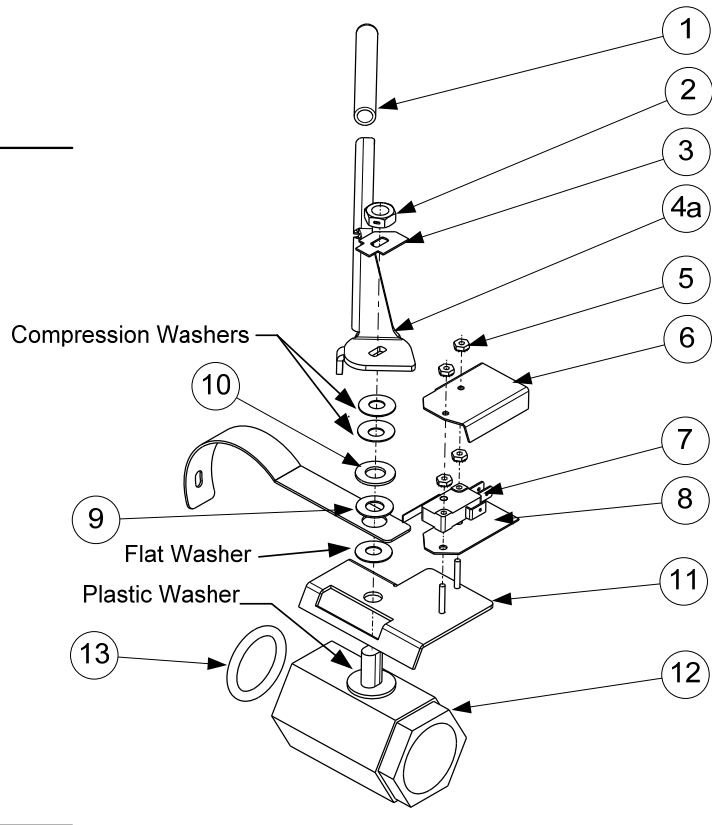

Dual-Vat Drain Valve
Left Assembly
106-5607 /
106-6301 Single FP

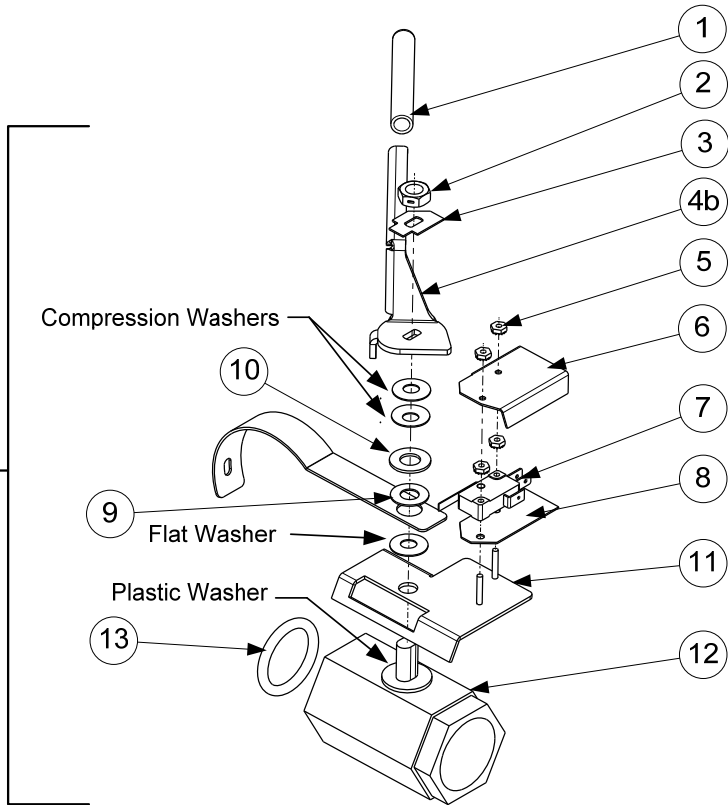

8.3.2 Drain Valve Assembly and Assoc. Parts cont. (Units with Built-In Filtration)

ITEM	PART#	COMPONENT
1	816-0639	Cap, Drain Handle
2	809-0539	Nut, 3/8-16 2-Way Hex Lock
3	900-2934	Retainer, Dual-Vat Drain Valve Nut
4a	824-1636	Handle, Dual-Vat Right Drain Valve
4b	824-1637	Handle, Dual-Vat Left Drain Valve
5	809-0237	Nut, 4-40 Keps Hex
6	901-2348	Cover, Dual Vat Drain Safety Switch
7	807-2103	Microswitch, CE Straight Lever
8	816-0220	Insulation, Drain Safety Switch
9	810-1165	Washer, Teflon Drain Valve
10	809-0196	Washer, 3/8-inch Flat
11	106-2671	Bracket Assembly, Dual-Vat Drain Safety Switch
	106-6304	Bracket Assembly, Dual-Vat Drain Safety Switch Single Footprint Only
12	810-1114	Valve, 1-inch Dual-Vat Drain
13	816-0135PK	Round Drain O-Ring (Qty 4)
*	823-5592	Tube, Drain Single-Station Only with Filter

* Not illustrated.

8.3.3 Drain Valves and Associated Parts (Units without Built-In Filtration)

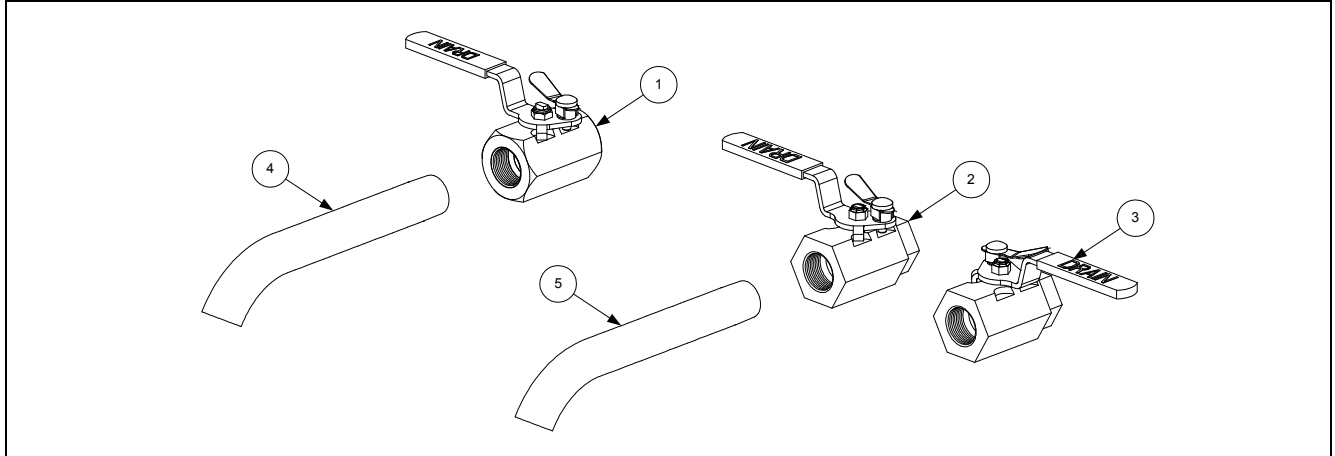

ITEM	PART #	COMPONENT
1	810-1569	Valve, 1.25-inch Non-Filter Full-Vat Drain
2	806-7915SP	Valve, 1-inch Non-Filter Dual-Vat Left Drain
3	806-7916SP	Valve, 1-inch Non-Filter Dual-Vat Right Drain
4	812-1226	Drain Extension, 1.25-inch
5	812-1227	Drain Extension, 1-inch

8.4 Electronics and Wiring Components
8.4.1 Component Boxes

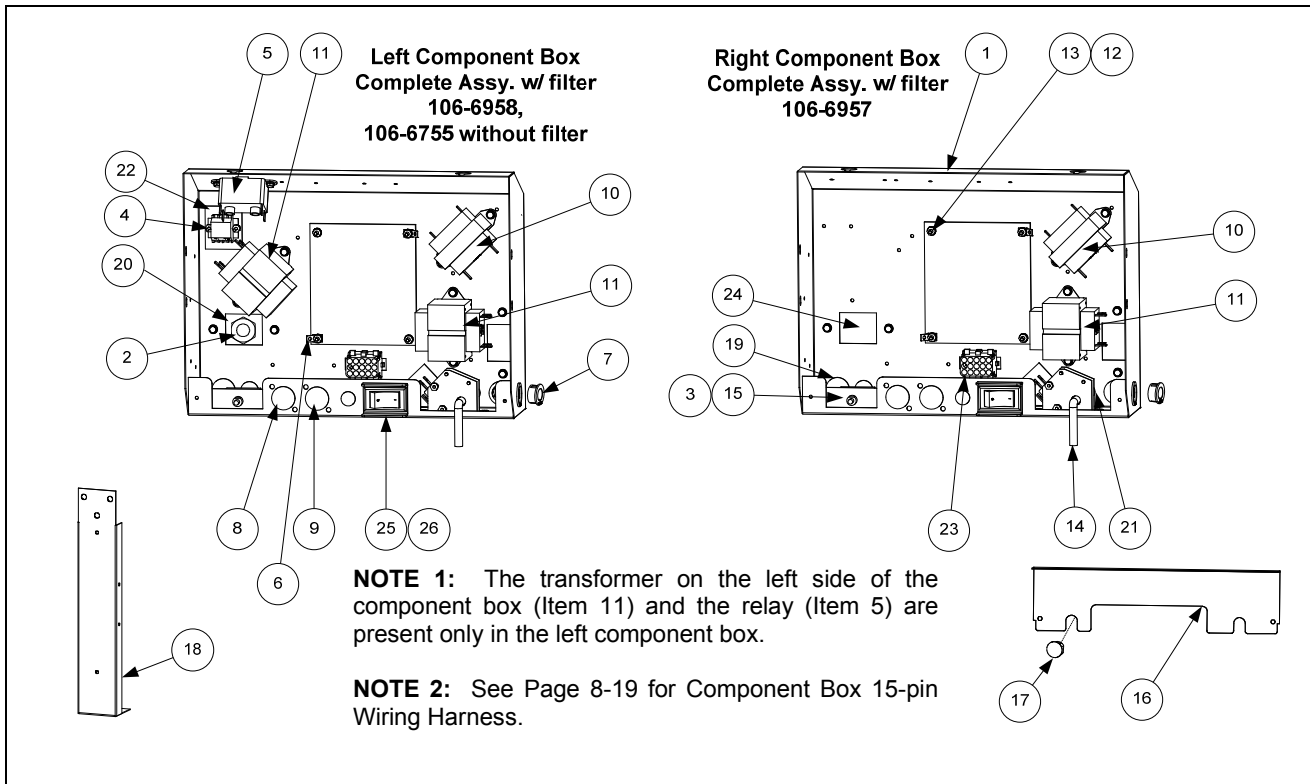

ITEM	PART #	COMPONENT
1	106-5846	Box Assembly, Component
2	210-9002	Bracket, Component Box Strain Relief
3	230-1057	Bracket, Circuit Breaker
4	806-9495SP	Terminal Block and Wire Assembly
5	807-0012	Relay, Filter 18 Amp 1/3 HP 24V Coil
6	826-1337	Terminal, 1/4-inch Push-on (Pkg. of 5)
7	810-0045	Bushing, .875 Dia. Hole 11/16"
8	807-1947	Plug, .875
9	810-2446	Plug, .50 Heyco Double "D"
10	807-0855	Transformer, 100-120V/12V 20VA
11	807-0800	Transformer, 100-120V/24V 50VA
*	807-3892	Transformer, 440/480 12/24V (Used in non-filter fryers)
12	809-0349	Spacer, 4mm X 6mm Aluminum
13	106-6811	Interface Board (<i>on Surface Mount Technology (SMT) boards the Relays are not replaceable</i>)
	807-3932	Relay, Heat/Latch 12VDC SPDT 12 Amp Sealed (<i>on SMT boards the Relays are not replaceable</i>)
*	807-4330	Sound Device Adaptor Harness
*	806-7179SP	Sound Device (<i>use 810-3141 for SMT Sound Device</i>)
14	106-5848	Handle Assembly, Oil Flush FV
15	807-0069	Circuit Breaker, 10 Amp
16	210-9118	Guard, Finger
17	810-2445	Plug, Button .625 Heyco Double "D"

* Not illustrated.

Continued on the following page.

8.4.1 Component Boxes cont.

ITEM	PART#	COMPONENT
18	210-8995	Brace, Component Box
19	807-1083	Bushing, Heyco
20	807-3868	Strain Relief
21	807-0121	Bushing, Heyco SB-625-500
22	816-0217	Paper, Insulating Terminal Block CE
23	106-5750	Harness, Full Vat Assembly
24	220-0083	Plate, Strain Relief
25	807-4036	Switch
	807-3575	Plug, Carling Switch Hole <i>(used in place of a switch on some models)</i>
26	230-0834	Guard, RE Box Switch

* Not illustrated.

8.4.2 Contactor Boxes

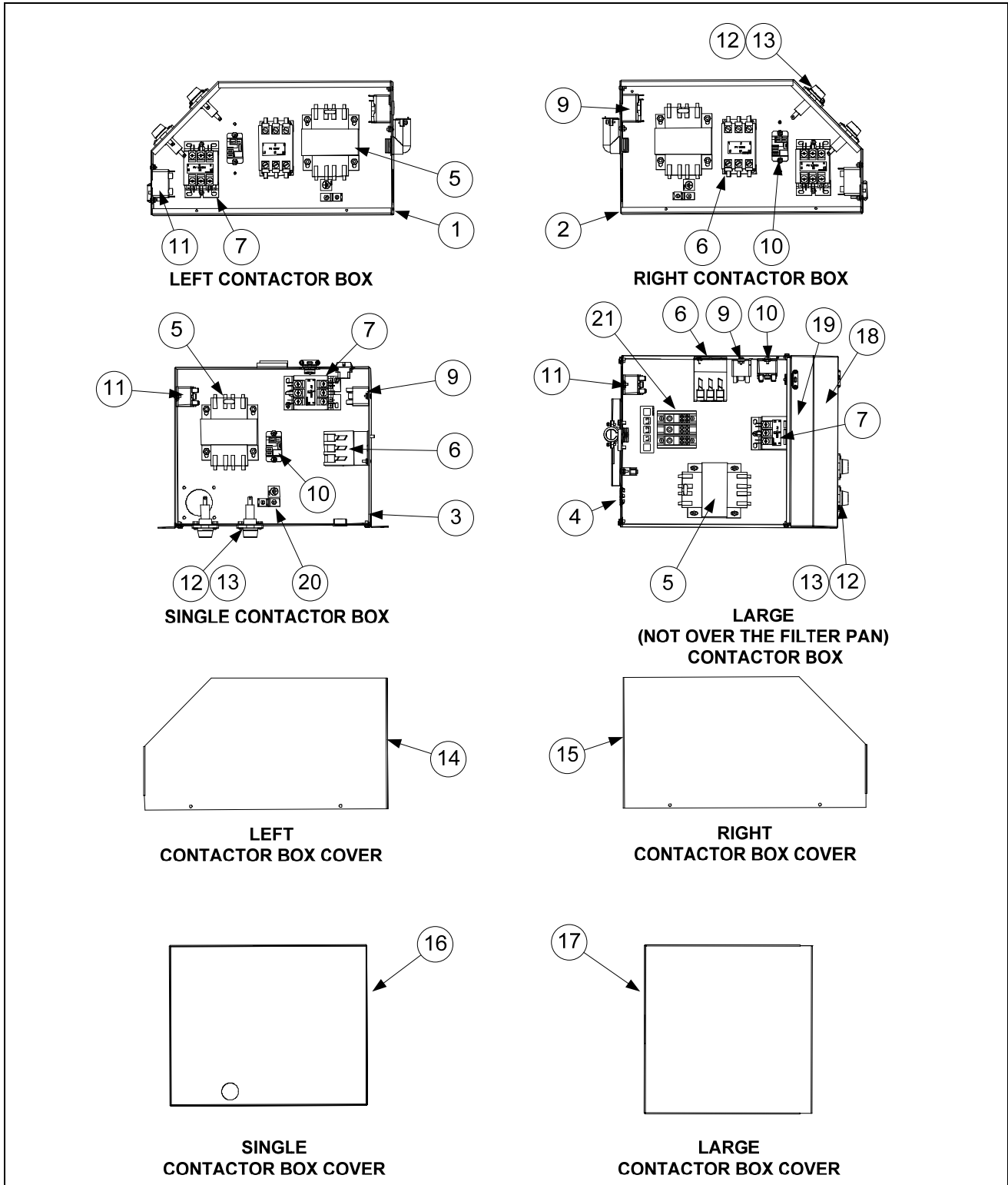

NOTE 1: Left and right contactor box assemblies are mirror images of one another. With the exception of the box itself, all components of a left-hand assembly, are the same as those in the corresponding right-hand assembly and vice versa.

NOTE 2: See Page 8-18 and 8-19 for Contactor Box Wiring Assembly

8.4.2 Contactor Boxes cont.

ITEM	PART #	COMPONENT
	106-8801	Assembly, Contactor Box Left
	106-8802	Assembly, Contactor Box Right
	106-6292	Assembly, Contactor Box Single
	106-6268	Assembly, Contactor Box Large (Not over the filter-pan box)
1	106-6124	Box, Left Contactor
2	106-6125	Box, Right Contactor
3	106-6288	Box, Single Footprint Contactor
4	106-6255	Box, Large Contactor (Not over the filter-pan box)
5	807-0031	Transformer, 250VA
	807-0064	Transformer, 480V/120V 150 VA <i>(used in fryers with filtrations systems only)</i>
6	807-6169	Contactor, 24V 50 Amp Mechanical <i>(used in 14 & 17kW units only)</i>
7	810-1202	Contactor, 24V 40 Amp Mechanical
8	807-2283	Contactor, 24V 63 Amp Mechanical <i>(used in 22kW units only)</i>
9	807-2434	Relay, Shunt 24V Coil Amp
10	807-1683	Relay, Power 12 VDC
11	807-0012	Relay, Tilt 18 Amp HP 24 V Coil
12	807-0922	Holder, Bus Fuse
13	807-2278	Fuse, 20 Amp
14	231-1135	Cover, Left Hand
15	232-1135	Cover, Right Hand
16	230-1377	Cover, Single Foot Print
17	220-1089	Cover, Large Top
18	220-1088	Cover, Contactor Box Front
19	220-1087	Bracket, Box Connecting
20	807-0070	Terminal, Ground Lug
21	807-3970	Block, Terminal 3 pole 600V 175A <i>(used in 22kW only)</i>
*	231-0811	Bracket, Left Hand Contactor Box Mounting
*	WIR0751	Wire Assembly, Filter Shunt Relay
*	WIR0726	Wire Assembly, Hood Relay
*	WIR0712	Wire Assembly, Latch/Heat Jumpers
*	232-0811	Bracket, Right Hand Contactor Box Mounting

*Not illustrated.

8.4.3 Heating Element Assembly and Associated Parts

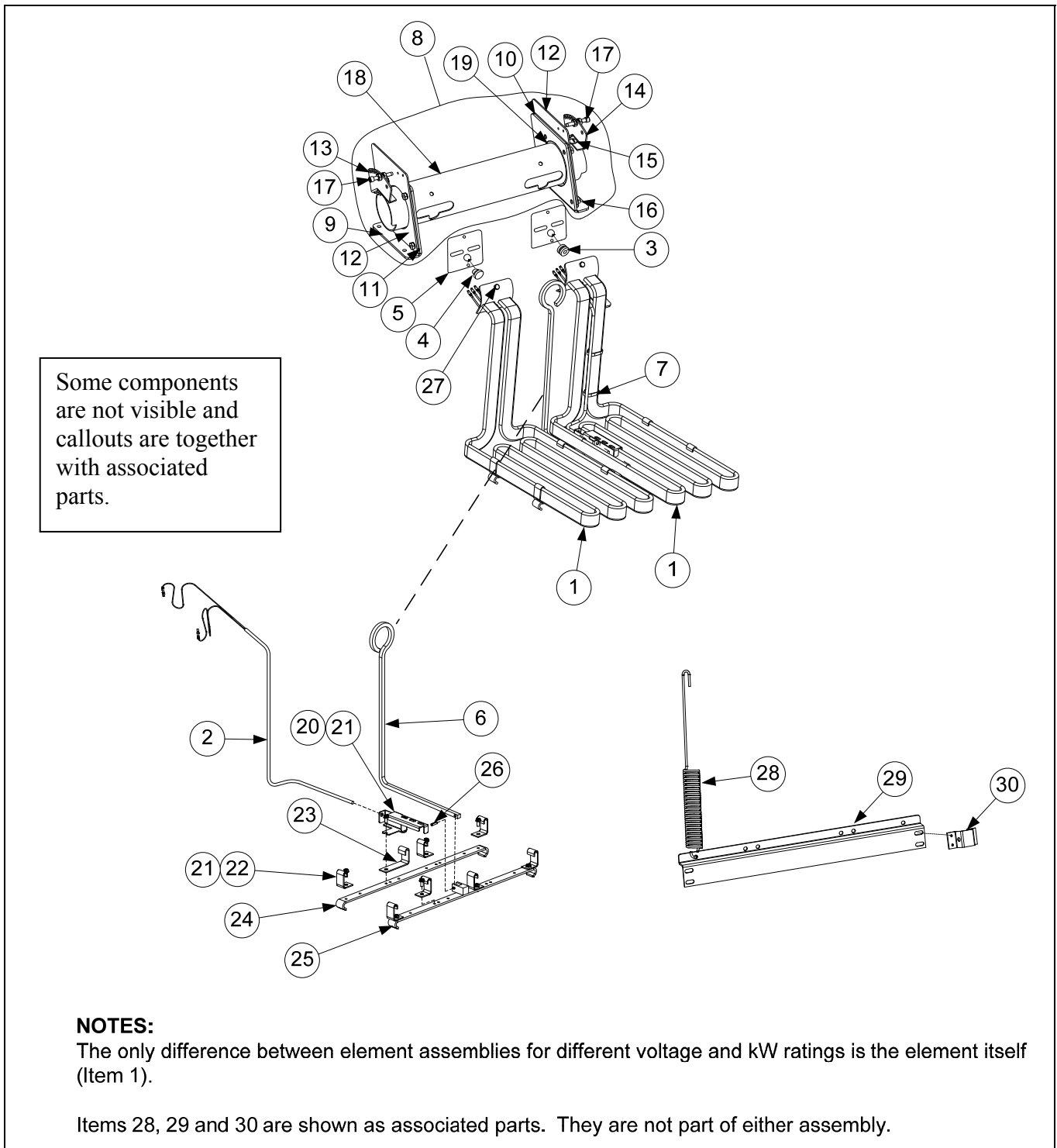

8.4.3 Heating Element Assembly and Associated Parts (cont.)

ITEM	PART #	COMPONENT
1		Element Kits – <i>includes gaskets, grommets, tie wraps, screws and nuts.</i>
	826-2195	440V 7.0 kW
	826-2202	440V 8.5 kW
	826-2211	440V 11.0 kW
	826-2196	480V 7.0 kW
	826-2203	480V 8.5 kW
	826-2209	480V 11.0 kW
2	826-2212	Probe, Temperature Kit (includes tie wraps and grommet)
3	816-0681	Grommet, Probe
4	816-0480	Plug, .375-inch Dome
5	816-0688	Gasket, Element
6	810-2971	Handle, Element Lift SS
7	809-0567	Tie-Wrap, Metal
8	106-5590	Tube Assembly Element, Full-Vat
9	106-5588	Bracket Assembly, LH Element Tube Support
10	106-5589	Bracket Assembly, RH Element Tube Support
11	230-0554	Plate, Element Tube Support Inner
12	230-0553	Plate, Element Tube Support Outer
13	106-6569	Bracket Assembly, LH Upper Spring
14	106-6570	Bracket Assembly, RH Upper Spring
15	826-1330	Screw, 10-32 X $\frac{3}{8}$ -inch Slotted Truss Head SS (Pkg. of 25)
16	809-0766	Nut, 10-32 Hex HD SS
17	809-1000	Screw, 10-32 x $1\frac{1}{4}$ -inch Hex
18	106-6037	Tube, FV Element Mounting
19	810-2993	Bushing, Tube End Teflon
20	230-0850	Bracket, Temperature Probe
21	809-0518	Screw, 8-32 X $\frac{3}{8}$ -inch Slotted Hex Head SS
22	210-9180	Clamp, Element (Short)
23	230-0781	Clamp, Element (Long)
24	230-0849	Bracket RE, Full-Vat Element Rear
25	823-5657	Bracket RE, Full-Vat Element Front
26	826-1364	Pin, .125 X .5-inch Split (Pkg. of 25)
27	809-1003	Screw, 10-32 X $\frac{3}{8}$ -inch Hex Head SS (uses 809-0766 nut 10-32 SS)
28	810-3030	Spring, Element Lift Left
	810-3031	Spring, Element Lift Right
29	220-0464	Bracket, Lower Spring
	220-1190	Bracket, Lower Spring Single Foot Print
30	220-0733	Bracket, Lower Spring Mating
*	106-6587	Magnetic Position Sensor
*	810-3007	Magnet
*	230-0794	Bracket, Magnetic Position Sensor Wire

* Not illustrated.

8.4.4 Controller

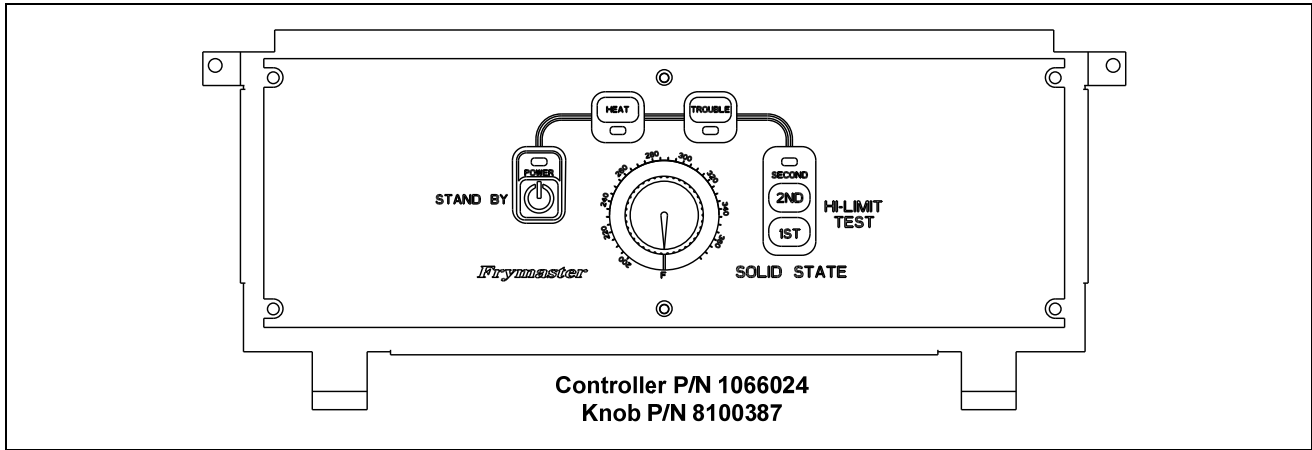

8.4.5 Wiring

8.4.5.1 Contactor Box Wiring Assembly – 12-Pin Full-Vat C-1

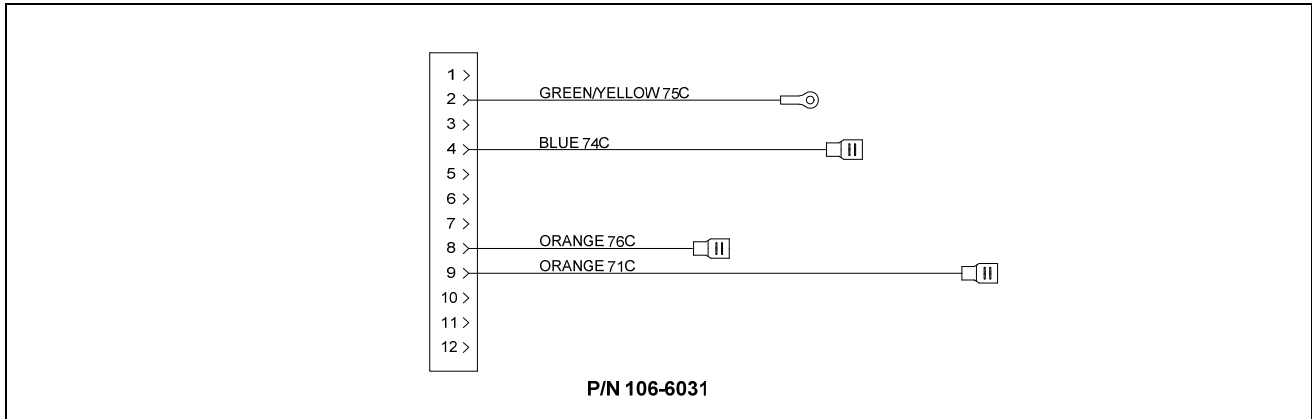

8.4.5.2 Contactor Box Wiring Assemblies – 6-Pin (Left Element)

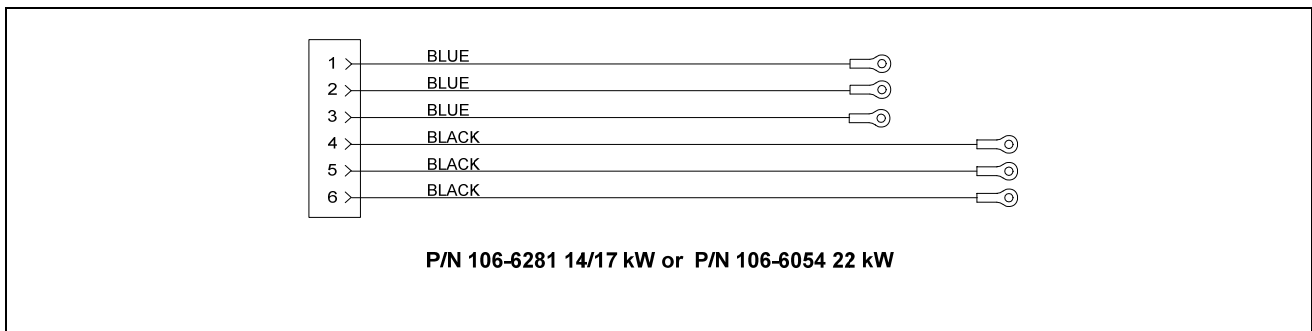

8.4.5.3 Contactor Box Wiring Assemblies – 9-Pin (Right Element)

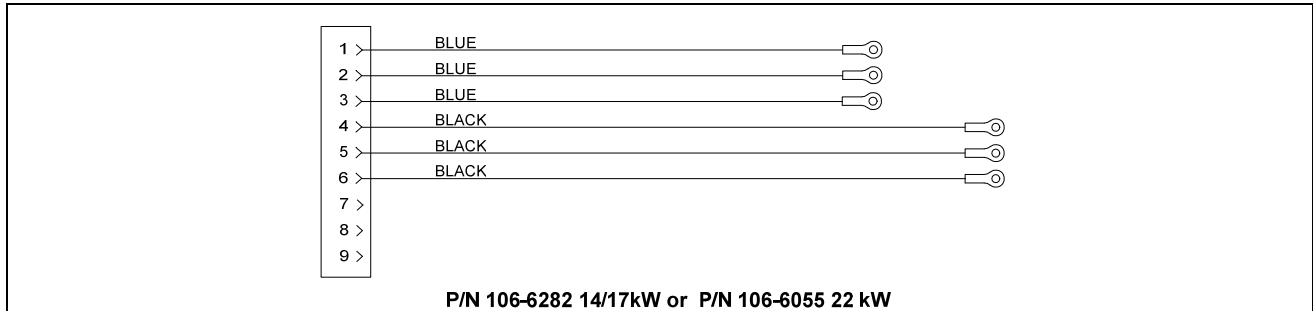

8.4.5.4 Main Wiring Harness

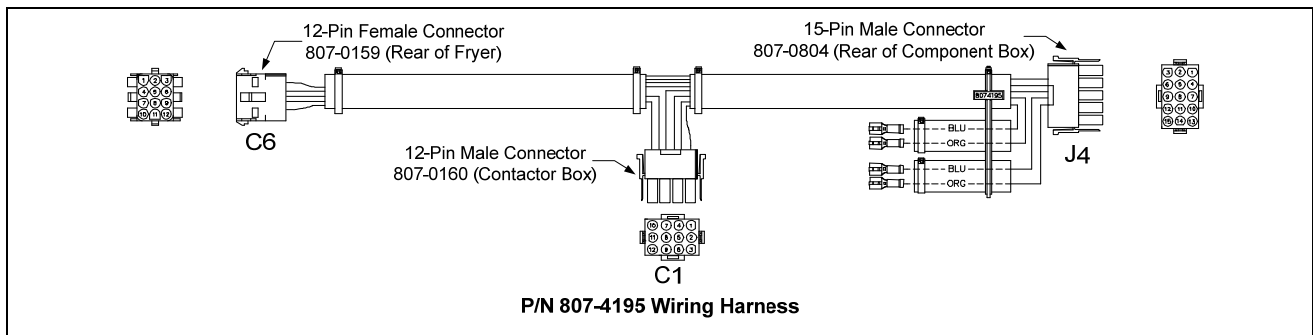

8.4.5.5 Component Box and Filter Pump Wiring Harnesses

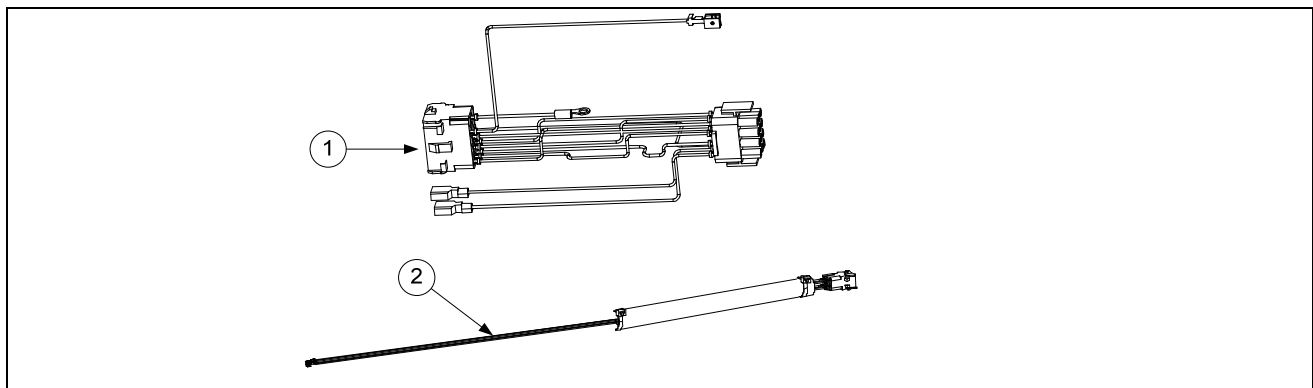

ITEM	PART #	COMPONENT
1	106-5750	Full Vat Control Harness J4 to J2 (<i>WIR0765 – Navy Jumper Wire Kit is needed with this harness</i>)
2	106-5935	Filter Pump C2 to Component Box Wiring Harness

8.4.5.6 Interface Board to Controller Wiring Harness – 15-Pin

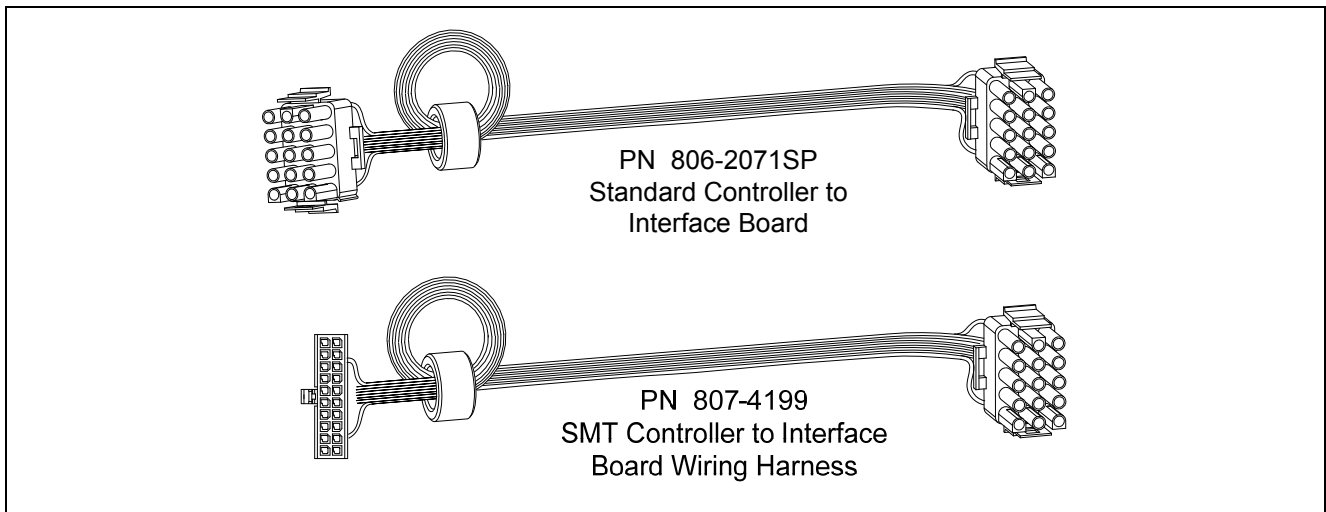

8.5 Filtration System Components

8.5.1 FPRE117 Filtration Components

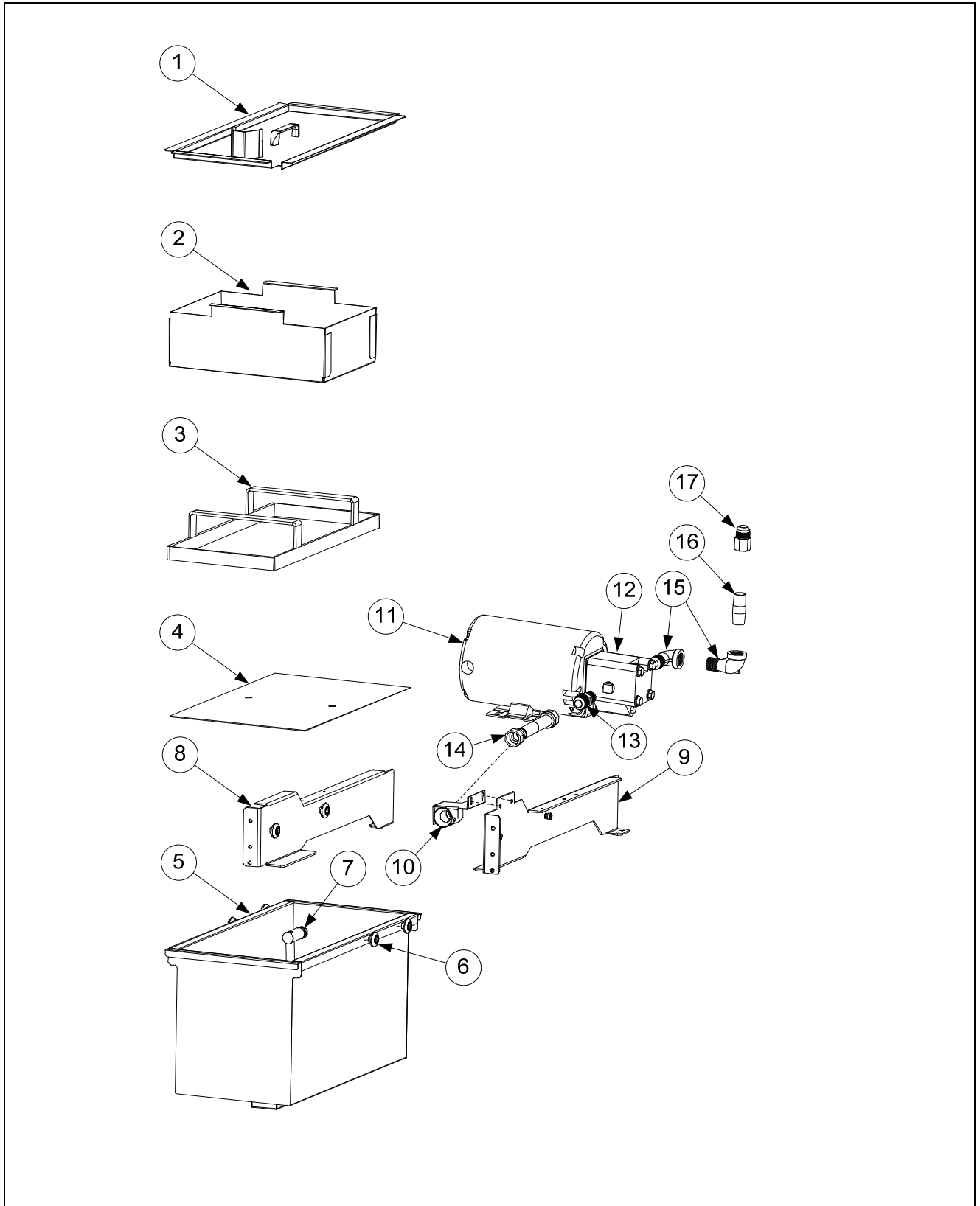

8.5.1 FPRE117 Filtration Components (cont.)

ITEM	PART #	COMPONENT
	106-5983	Assembly, Filter Pan Single includes pan and lid
1	106-6243	Lid, Single
2	824-1707	Crumb Tray
3	823-5774	Hold Down Ring - Paper
4	220-1316	Sana Grid Filter Screen
5	823-5594	Pan, Filter
6	810-2198	Roller, Filter Pan Rail (used with Item 8 and 9)
*	826-1979	Filter Pan Roller Kit (four each of Items 6 and 826-1372)
*	826-1372	Nut, 1/4-20 Hex (Pkg. of 10)
*	810-2012	Rail Set, Filter Pan Roller (includes one left and one right)
7	826-1392	O-Ring (Pkg. of 5; used with Item 5)
8	106-5981	Support, Assy. Left Filter Pan
9	106-5982	Support, Assy. Right Filter Pan
10	823-5591	Fitting, Female Suction Tube
11	826-1270	Motor and Gasket Kit, 220-240V 50/60Hz
12	826-1264	Pump and Gasket Kit
	810-2716	Pump, Viking 4GPM 2-piece
	816-0093	Gasket, Pump/Motor
*	807-11973	Viking Pump Seal Kit
13	810-1668	Adapter, 5/8-inch to 1/2-inch NPT Male
14	810-1680	Flexline, 6.5-inch Oil Return
15	813-0165	Elbow, ST 1/2-inch x 1/2-inch NPT 90° BM
16	813-0298	Nipple, 1/2-inch 2.0-inch
17	810-1669	Adapter, 5/8-inch to 1/2-inch NPT Female
*	106-2852SP	Heater Strip Assembly, 208-250V 25W 18"

* Not illustrated.

8.5.2 Multiple Battery Filtration System Components

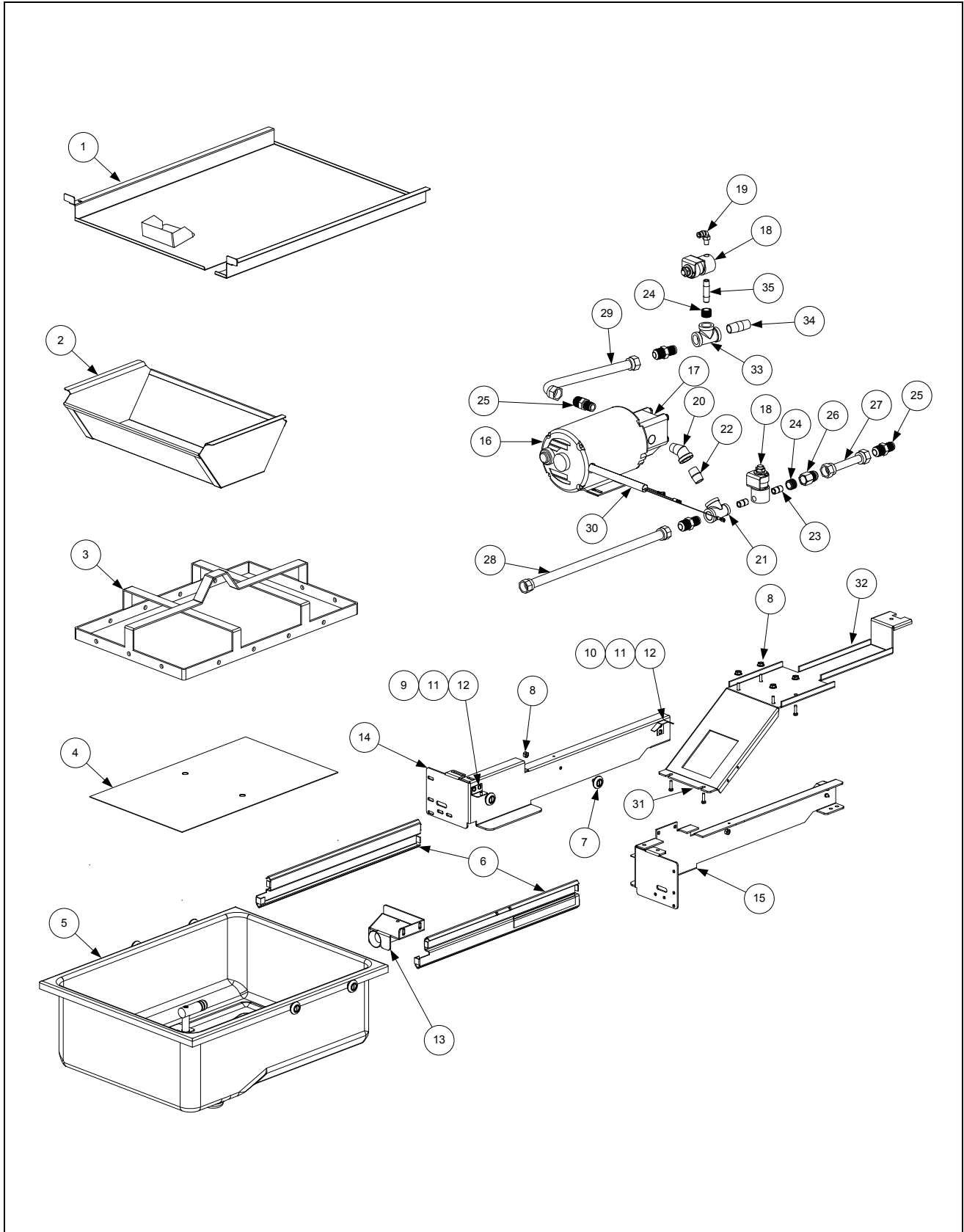

8.5.2 Multiple Battery Filtration System Components (cont.)

ITEM	PART #	COMPONENT
*	826-1979	Filter Pan Roller Kit (four each of Items 7 and 8)
*	826-1392	O-Ring (Pkg. of 5; used with Item 5)
*	813-0568	Plug, 1/8-inch Socket Head Pipe (component of Item 5; two required)
*	811-1071	Tubing, 1/4-inch OD Teflon Vent (sold by the foot)
*	806-5933SP	Heater Strip Assembly, 120V 18" 25W
1	823-6543	Lid
2	810-2874	Crumb Tray
3	810-2910	Hold Down Ring
4	812-2024	SanaGrid Filter Screen
5	108-1234SP	Pan, One-Piece Filter
6	810-2012	Rail Set, Filter Pan Roller (includes one left and one right)
7	810-2198	Roller, Filter Pan and Rail
8	826-1372	Nut, 1/4-20 Hex (Pkg. of 10)
9	823-4675	Bracket, Lid Support
10	200-3556	Guide, Filter Pan Lid
11	809-0503	Screw, 8-32 X 1/2-inch Slotted Truss Head
12	809-0247	Nut, 8-32 Hex Keps
13	823-3879	Suction Tube
14	200-4408	Rail, Left Filter
15	200-4409	Rail, Right Filter
16	826-1712	Kit, Motor and Gasket 115V 60Hz
17	826-1264	Pump and Gasket Kit 4 GPM 2-piece
	816-0093	Gasket, Pump/Motor
*	807-11973	Pump Seal Kit
18	807-2484	Valve, 1/4-inch Solenoid
19	813-0165	Elbow, 1/2-inch 90° Street
20	813-0342	Elbow, 1/2-inch 45° Street
21	813-0530	Tee, 1/2-inch X 1/4-inch X 1/2-inch Reducing
22	813-0022	Nipple, 1/2-inch Close
23	813-0838	Nipple, 1/4-inch Close
24	813-0304	Bushing, 1/2-inch to 1/4-inch Flush
25	810-1668	Adapter, 5/8-inch to 1/2-inch NPT Male
26	810-1669	Adapter, 5/8-inch to 1/2-inch NPT Female
27	810-1159	Flexline, 5.0-inch Oil Return
28	810-1057	Flexline, 13.0-inch Oil Return
29	810-1055	Flexline, 11.5-inch Oil Return
30	807-3828	Cable, FootPrint Pro Pump Motor
31	826-1375	Screw, 10-32 X 3/4-inch Hex Trim Head (Pkg. of 5)
32	200-7112	Bridge, Filter Motor
33	813-0003	Tee, 1/2-Inch
34	813-0298	Nipple, 1/2-inch 2.0-inch
35	813-0537	Nipple, 1/4-inch 2.0-inch
*	810-1043	Flexline, 9.5-inch Oil Return

* Not illustrated.

8.6 Frypot Assembly and Thermostat

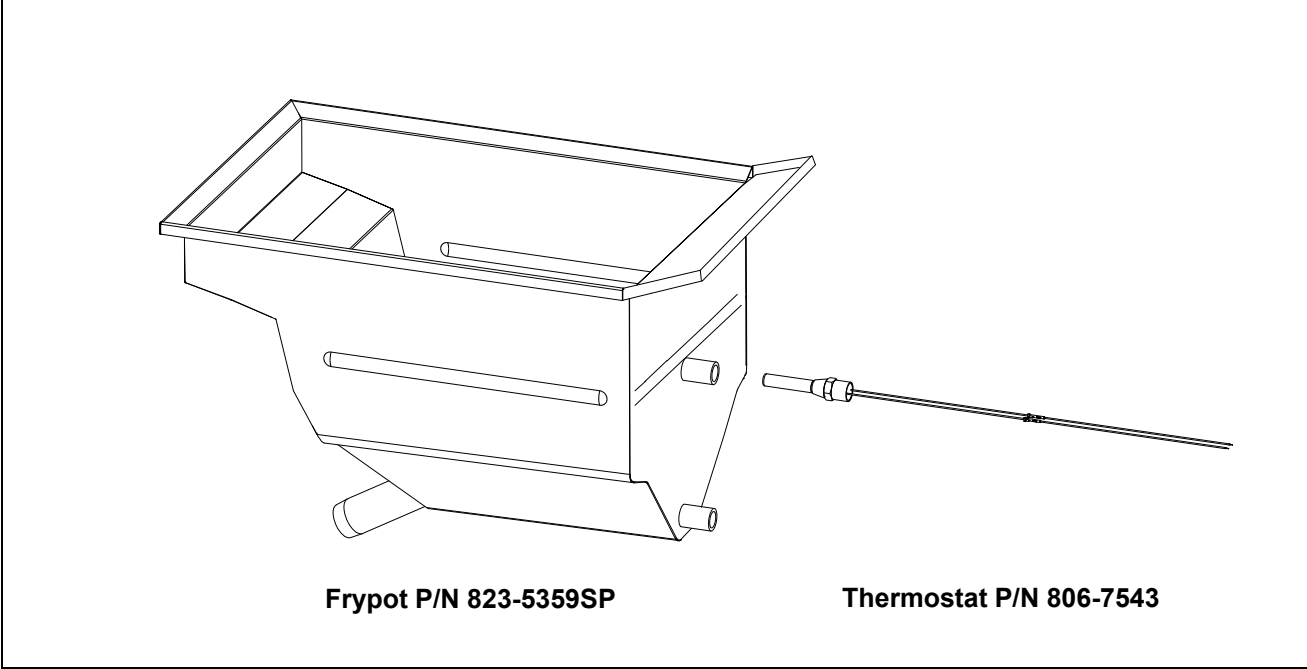

8.7 Oil Return System Components

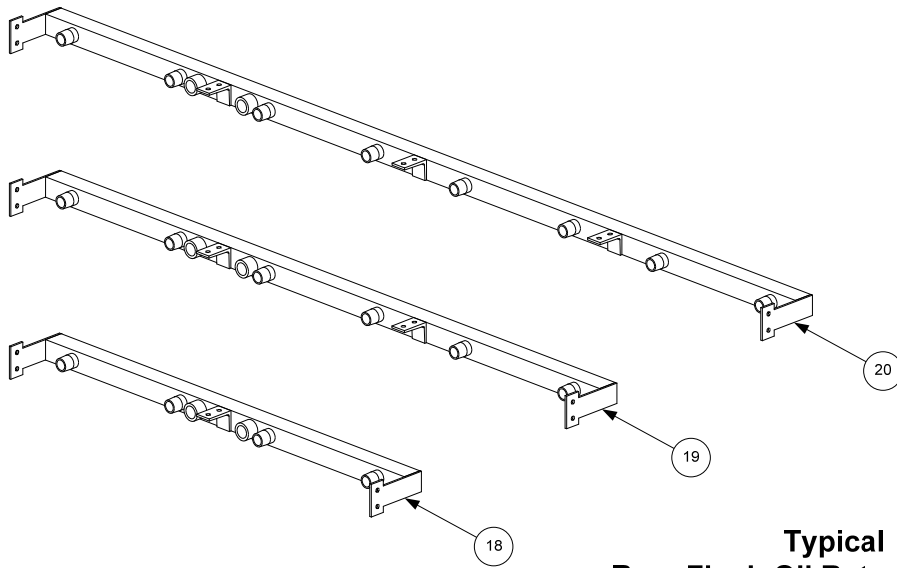

Typical Rear-Flush Oil Return Plumbing

Plumbing for a two-fryer battery is illustrated, but all components except the oil return manifold are the same regardless of the number of fryers in the battery.

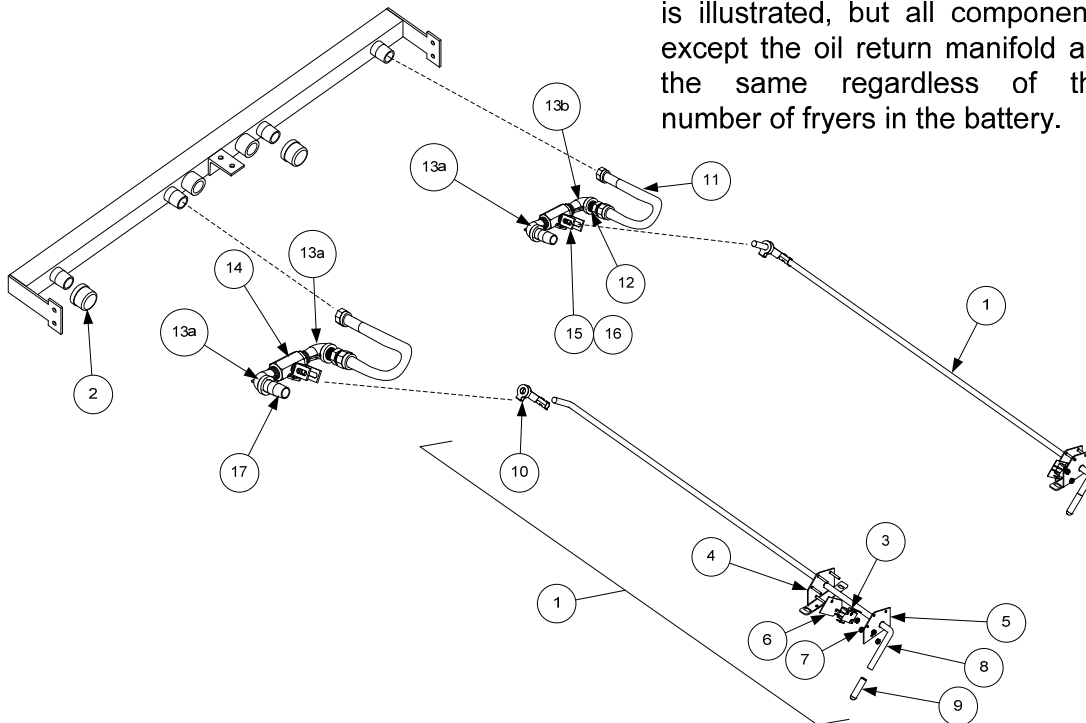

8.7 Oil Return System Components (cont.)

ITEM	PART #	COMPONENT
1	106-5848	Handle Assembly
2	813-0907	Cap, 15/16-inch Valve Safety
3	807-2103	Microswitch, Straight Lever
4	106-5847	Bracket Assembly, Microswitch
5	210-8998	Bracket, Handle Retainer
6	816-0220	Insulation, Oil Return Microswitch
7	826-1366	Nut, 4-40 Keps Hex (Pkg. of 25)
8	810-3034	Rod, Filter Handle
9	816-0643	Grip, Oil Return Valve Handle
10	809-0601	Clip, Clevis
11	810-2532	Flexline, 7.0-inch
12	810-1668	Adapter, 5/8-inch to 1/2-inch NPT Male
13a	813-0165	Elbow, 1/2-inch X 90° Street
13b	813-0908	Adapter, 1/2-inch NPT M/T 90° <i>(used only on side next to cabinet)</i>
14	810-2944	Valve, 1/2-inch Ball
15	200-5438	Handle, Rear Flush Valve
16	900-2935	Retainer, Oil Return Valve Nut
17	813-0460	Nipple, 1/2-inch X 3.0-inch NPT
18	810-3015	Manifold, Two-Station Fryer <i>(use 810-2543 for non-filter units)</i>
19	810-3016	Manifold, Three-Station Fryer <i>(use 810-2544 for non-filter units)</i>
20	810-3017	Manifold, Four-Station Fryer <i>(use 810-2545 for non-filter units)</i>

8.8 Wiring Connectors, Pin Terminals and Power Cords

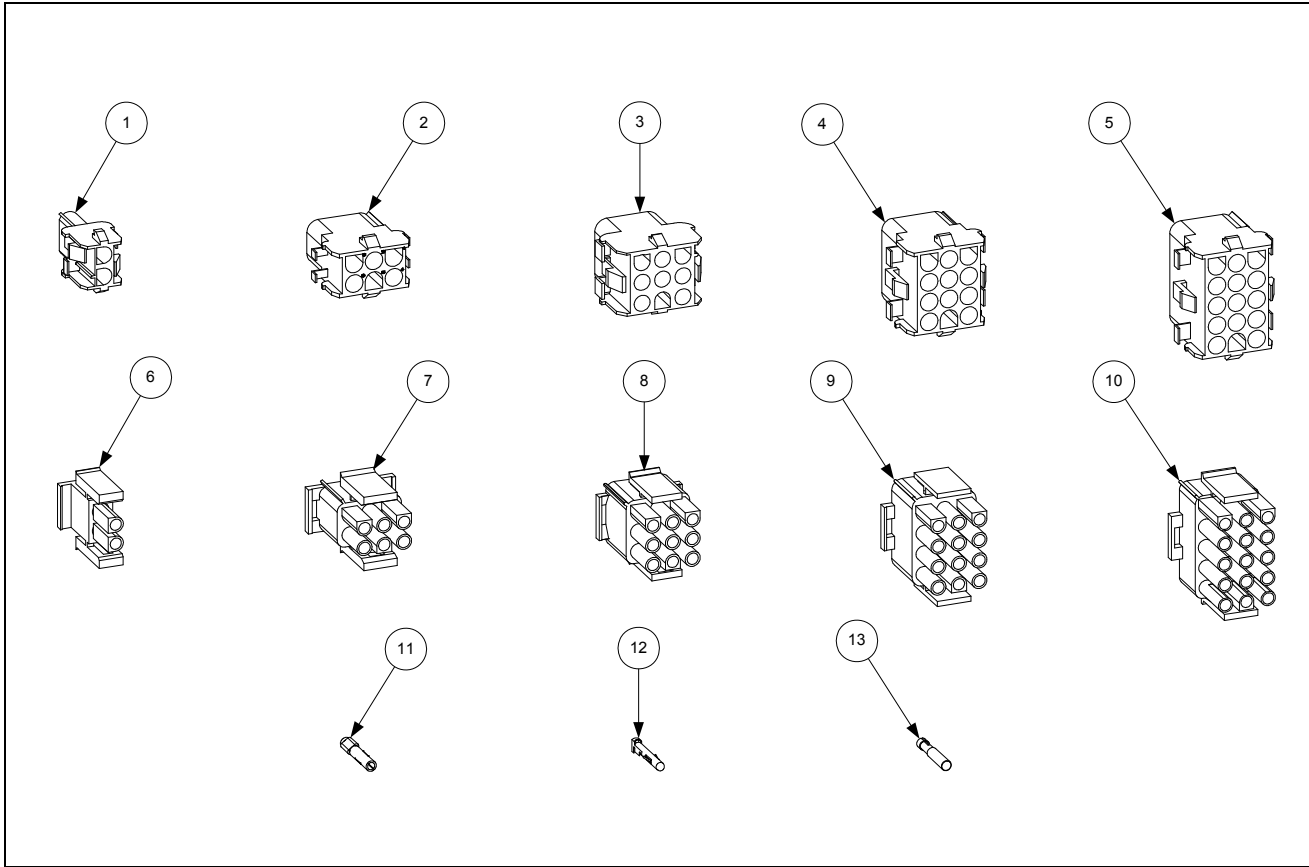

ITEM	PART #	COMPONENT
		Power Cords
*	807-3834	Cable, 3-Phase 4-Wire (Fryer Power Cable)
*	807-3825	Cord, Filter System Power
		Connectors
1	807-1068	2-Pin Female
2	807-0158	6-Pin Female
3	807-0156	9-Pin Female
4	807-0159	12-Pin Female
5	807-0875	15-Pin Female
6	807-1067	2-Pin Male
7	807-0157	6-Pin Male
8	807-0155	9-Pin Male
9	807-0160	12-Pin Male
10	807-0804	15-Pin Male
11	826-1341	Terminal, Female Split Pin (Pkg of 25)
12	826-1342	Terminal, Male Split Pin (Pkg of 25)
13	807-2518	Plug, Mate-N-Lock (Dummy Pin)

* Not illustrated.

8.9 Fasteners

ITEM	PART #	COMPONENT
*	809-0429	Bolt, 1/4-inch – 20 x 2.00-inch Hex Head ZP Tap
*	809-0514	Capscrew, 5/16-inch-18 NC Hex
*	809-0448	Clip, Tinnerman
*	826-1366	Nut, 4-40 Keps Hex (Pkg. of 25) (809-0237)
*	826-1358	Nut, 6-32 Keps Hex (Pkg. of 25) (809-0049)
*	809-0247	Nut, 8-32 Keps Hex
*	826-1376	Nut, 10-32 Keps Hex (Pkg. of 10) (809-0256)
*	809-0766	Nut, 10-32 Keps Hex SS
*	809-0581	Nut, 1/2 NPT Locking
*	809-0020	Nut Cap 10-24 NP
*	826-1372	Nut Grip 1/4-inch 1/4-20 Hex NP (Pkg. of 10) (809-0059)
*	809-0417	Nut Flange 1/4-inch 1/4-20 Serr
*	809-0535	Nut, "T" 1/4-inch-20 x 7/16 SS
*	809-0540	Nut, Lock 1/2-inch-13 Hex 2-Way ZP
*	826-1359	Screw, 4-40 x 3/4-inch Slotted Round Head (Pkg. of 25) (809-0354)
*	826-1365	Screw, 6-32 x 3/8-inch Slot Head (Pkg. of 25) (809-0095)
*	809-0357	Screw, 6 x 3/8-inch Phillips Head NP
*	809-0359	Screw, 8 x 1/4-inch Hex Washer Head
*	809-0360	Screw, 8 x 3/8-inch Hex Washer Slot Head
*	826-1371	Screw, 8 x 1/2-inch Hex Head ZP (Pkg. of 25) (809-0361)
*	809-0364	Screw, 8 x 5/8-inch Hex Washer Head ZP
*	809-0518	Screw, 8-32 x 3/8-inch Hex Washer Slotted Head SS
*	809-0104	Screw, 8-32 x 1/2-inch Slotted Head ZP
*	826-1363	Screw, 8-32 x 1/2-inch NP (Pkg. of 25) (809-0103)
*	826-1360	Screw, 10-24 x 5/16-inch Round Slot Head ZP (Pkg. of 25) (809-0024)
*	826-1330	Screw, 10-32 x 3/8-inch Slot Head SS (809-0117)
*	809-1003	Screw, 10-32 x 3/8-inch Hex Trim Head SS
*	826-1375	Screw, 10-32 x 3/4-inch Hex Trim Head SS (Pkg. of 5) (809-0401)
*	809-1000	Screw, 10-32 x 1 1/4-inch Hex Sck C/S
*	826-1374	Screw, 10 x 1/2-inch Hex Head (Pkg. of 25) (809-0412)
*	809-0266	Screw, 10 x 1/2-inch Phillips Head ZP
*	809-0434	Screw, 10 x 3/8-inch Hex Washer Head NP
*	809-0123	Screw, 10 x 3/4-inch Slot Head
*	826-1389	Screw, 1/4-20 x 3/4-inch Hex Head ZP (Pkg. of 10) (809-0131)
*	809-0582	Washer 1/2 NPT Locking
*	809-0184	Washer, #10 LK ZP
*	809-0190	Washer, .625 X .275 X 40 Flat SS
*	809-0191	Washer, Lock 1/4 Spring ZP
*	809-0193	Washer, Flat 1/4 Nylon
*	809-0194	Washer, Flat 5/16 ZP

THIS PAGE INTENTIONALLY LEFT BLANK

**WELBILT®***Bringing innovation to the table***WWW.WELBILT.COM**

Welbilt provides the world's top chefs, and premier chain operators or growing independents with industry leading equipment and solutions. Our cutting-edge designs and lean manufacturing tactics are powered by deep knowledge, operator insights, and culinary expertise. All of our products are backed by KitchenCare® – our aftermarket, repair, and parts service.

▼ CLEVELAND ▼ DELFIELD® ▼ FRYMASTER® ▼ KOLPAK® ▼ MANITOWOC® ▼ MERRYCHEF®
▼ CONVOTHERM® ▼ FITKITCHEN™ ▼ GARLAND ▼ LINCOLN ▼ MERCO® ▼ MULTIPLEX®